



Florida State University

Telecommunications Infrastructure Standard

Revision 2.2g

May 22, 2006

Document developed by:

Office of Telecommunications
Operations Division

REVISION HISTORY4
INTRODUCTION11
I. CONDUIT AND MANHOLE SYSTEM13
A. SERVICE ENTRANCE13
B. MANHOLE15
C. OUTSIDE PLANT CONDUIT (INTER BUILDING)15
D. HORIZONTAL PATHWAY DISTRIBUTION SYSTEMS (INTRA BUILDING)17
E. MISCELLANEOUS DISTRIBUTION SYSTEMS21
F. INTRABUILDING BACKBONE RISER CONDUIT22
II. TELECOMMUNICATIONS ROOMS / EQUIPMENT ROOMS23
A. DEFINITION23
B. REQUIREMENTS24
III. MEDIA32
A. OUTSIDE PLANT CABLING32
B. INTRABUILDING BACKBONE DISTRIBUTION CABLING34
C. HORIZONTAL DISTRIBUTION CABLING39
IV. TERMINATION43
A. WALL AND RELAY RACK LAYOUT CONSIDERATIONS43
B. INTRABUILDING BACKBONE RISER TERMINATION45
C. HORIZONTAL TERMINATIONS46
D. CROSS-CONNECTS50
E. LABELING51
V. TELECOMMUNICATIONS GROUNDING AND BONDING52
A. GROUNDING PRACTICES52
B. TELECOMMUNICATIONS BONDING PRACTICES52
C. TELECOMMUNICATIONS GROUNDING AND BONDING BACKBONE.53
D. TYPICAL TELECOMMUNICATIONS GROUNDING AND BONDING SYSTEM.55
VI. TESTING56
VII. OTC RECOGNIZED MATERIALS56
VIII. OTHER61
A. CAMPUS MASTER PLAN61
B. INSPECTION AND TESTING INSTALLATION61
C. COIN OPERATED TELEPHONES61

D.	BLUE LIGHT EMERGENCY TELEPHONES61
E.	ELEVATOR PHONES62
F.	WIRELESS APPLICATIONS62
G.	DOCUMENTS62
IX.	APPLICABLE CODES AND STANDARDS62
X.	GLOSSARY OF TERMS64
XI.	ILLUSTRATIONS70
	A. FIG 1 – RISER CONDUIT LAYOUT71
	B. FIG 2 – TYPICAL BACKBOARD LAYOUT72
	C. FIG 3 – TYPICAL TELECOMMUNICATIONS ROOM73
	D. FIG 4 – TYPICAL VOICE TERMINAL CAN LAYOUT74
	E. FIG 5 – VOICE TERMINATION BLOCK CONFIGURATION75
	F. FIG 6 – KRONE FACEPLATE CONFIGURATION76
	G. FIG 7 – KRONE CATEGORY 5E INSERT77
	H. FIG 8 – TYPICAL RELAY RACK LAYOUT78
	I. FIG 9 – ELEVATOR TELEPHONE TEMPLATE79

Questions or comments concerning this document should be directed to:

Larry E. Downing, RCDD
 Manager, Technology and Infrastructure
 Florida State University
 Office of Telecommunications Engineering Group
 902 Wildwood Ave.
 Tallahassee, Florida 32306-1120

REVISION HISTORY

Subsequent modifications are listed below:

<u>Rev</u>	<u>Date</u>	<u>Change</u>
1.0	6/12/92	-Document created with IRM assistance
1.1	7/15/92	-Minor editorial changes
1.2	8/26/92	-ADA Act added to standard compliance
1.3	9/6/92	-Level 5 wiring added (CDDI)
1.4	9/16/92	-Revision foot note on each page -Special usage room requirements -Table of contents
1.5	10/6/92	-Minor editorial changes and format changes -Clarify high voltage conduit conflicts in relationship to telco conduit -Clarify conduit run lengths vs location of pull boxes -Change 100 m individual conduit length runs to 90 m -Define MDF vs IDF -Redefine equipment room sizes (IDF and MDF) -Clarify contiguous wall space requirements MDF vs IDF -Add information on how to key lockable MDF and IDF panels -Add RFI/EMI electrical, overhead clearances conflicts to equipment room -Remove all 20 mbps references and replace with 100 Mbps -Remove all specific references to vendors in data wiring sections -Add 25 pair level 5 riser to vertical riser section -Add EIA/TIA TSB-36 and TSB-40 to standards -Identify and outline customer premise equipment (CPE) room
1.5 (a)	11/18/92	-Quantify high voltage electric conduits better -Change DRAFT to Draft in Progress -Better define hand hole in B. <u>MANHOLE</u> section -Quantify when the OTC will start record keeping and assignment of any cables within the OSP system -Change qty 5 ea. 1” to qty 3 ea. 1 “ in Zoned Conduit System section -Add diagram of ceiling race way and spec out -Add laboratories to special usage areas -Rewrite section, <u>Conduit and Manhole System, F. Conduit Run Length</u> -Change MDF and IDF room dimensions to accommodate a longer single wall -Add table showing linear , contiguous wall space for MDF’s

- Remove foot note on linear , contiguous wall space for MDF's
 - Minor editorial changes
- 1.6 11/30/92
- Change all mbps references to Mbps
 - All uninterruptible power supply to emergency backup
 - Minor editorial changes
 - Place all vertical riser conduit next to wall with plywood
 - Add open office space/modular furniture to special application areas
 - Reformat outline in MEDIA section
 - Reformat content of MEDIA section to better reflect continuity of specifications
 - Change references to level 5 STP to read level 4 STP
 - Change reference to vertical rows in TERMINATION section to read vertical columns
- 1.6 (a) 12/1/92
- Add overhead racking Attachment 6 and reference CONDUIT AND MANHOLE SYSTEM, D, 3.
 - Minor editorial changes
- 1.6 (b) 1/6/93
- Replace attachment # 1,2,3,4,5 with new revision
 - Minor editorial changes
- 1.6 (c) 4/22/93
- Editorial changes
 - Cover page changes
 - Fiber optic cable optical performance changes
- 1.6 (d) 6/1/93
- Add homerun conduit from fire and alarm panels to IDF rooms
- 1.6 (e) 10/25/93
- Deeper gang boxes at termination end of conduit runs (2 1/2" deep)
 - Clarify that no obstructions shall go through ceiling raceways
 - Clarify that no janitors rooms shall be placed in IDF or MDF rooms
 - Clarify that ceiling raceway shall be used in conjunction with conduits stubbed above ceiling and ran back to the ceiling raceway.
 - Conduits run in slabs or other concrete structures shall be PCV Sch 40.
- 1.6 (f) 6/10/94
- Remove "Draft in Progress" from front title sheet
 - Clarify voice cabling specification to state (CAT3)
 - Clarify that all cabling installed under grade shall be fill cable
 - Change single mode fiber connectors to SC
- 1.6 (g) 3/13/96-Ceiling distribution systems design preference rearranged
- Define the physical size of pull boxes in horizontal conduits runs
 - Covers for 4" square gang boxes defined
 - Replace Newton cable tray with Atlas Center Hung Cable Tray
 - Add Telecom Room (TC) terminology to vertical distribution section

- Remove verbiage on painted/sealed floors in MDF/IDF rooms. Replace with VCT covering only.
- Add room layout verbiage to equipment room requirements
- Addition of wireless verbiage in OTHER section of specification
- Added verbiage to INSPECTION AND TESTING INSTALLATION section to assure test results get to OTC
- MASTER PLAN section renamed to CAMPUS MASTER PLAN
- Added more information outlets in classrooms
- Minor editorial changes
- Change AT&T 110 to Krone 66 type terminal devices

2.0 2/1/2000

MAJOR UPDATE

- Addition of underground entrance conduit recommendations.
- Addition of spare conduit to requirement for recommended entrance conduit counts.
- Added references to building entrance buried and aerial cable section.
- Added manhole interior hardware list.
- Added concrete strength for manholes – 3500 psi.
- Added outside plant conduit ductbank requirements.
- Added special outside plant applications.
- Added recommended design guidelines to horizontal pathway /conduit.
- Added design guidelines to horizontal pathway / cable tray.
- Added elevator conduit requirements to horizontal pathway special consideration section.
- Added ADA requirements to horizontal pathway special consideration section.
- Changed Vertical Riser section to Intrabuilding backbone Riser Conduit System.
- Added location, height and installation recommendations for riser sleeves to riser conduit design section.
- Changed section II from Equip rooms to telecom rooms and equip rooms.
- Changed name of main telecom room from MDF to MTC.
- Changed name of telecom rooms from IDF to TC.
- Added serving floor space recommendations for TC's.
- Added restrictions on other utilities and services sharing MTC and TC's.
- Changed wall coverage of plywood in MTC and TC to include all walls.
- Added installation requirements of plywood on walls in MTC and TC.
- Added lighting requirement section for MTC and TC.
- Added power requirements section for MTC and TC.
- Added room size recommendation section for MTC and TC.
- Added work clearance section for MTC and TC.
- Added RFI/EMI section for MTC and TC.

- Added pathway installation section for MTC and TC.
- Added ceiling section for MTC and TC.
- Added location section for MTC and TC.
- Changed door height and optional lock-box to entry section for MTC and TC.
- Added vertical stacking of rooms and conduit/sleeve recommended layout for MTC TC rooms.
- Added Fire Protection section to MTC and TC.
- Added environmental control section to MTC and TC.
- Added wall lining section to CPE rooms.
- Added lighting section to CPE rooms.
- Added power section to CPE rooms.
- Added rooms size section to CPE rooms.
- Added RFI/EMI section to CPE rooms.
- Added pathway section to CPE rooms.
- Added ceiling section to CPE rooms.
- Added locations section to CPE rooms.
- Added entry section to CPE rooms.
- Added conduit alignment to room layout of CPE rooms.
- Added fire protection section to CPE rooms.
- Added environmental section to CPE rooms.
- Added depth and plywood requirement for inside of terminal boxes.
- Added lighting section to CPE rooms.
- Added Power section to CPE rooms.
- Added grounding section to CPE rooms.
- Added configuration of conduits to CPE room section.
- Added outside plant section to media chapter.
- Added topology section to Intrabuilding backbone distribution cabling section.
- Specified data cables be used with special circuits.
- Specified voice backbone riser cable shall be Category 3 or higher.
- Added codes and standards referencing riser cable.
- Added CATV coaxial intrabuilding backbone section.
- Added Optic Fiber backbone riser section.
- Added Special data applications riser setion.
- Added code considerations for intrabuilding backbone riser cables.
- Changed Riser Termination Wiring section to Intrabuilding Backbone Cross-connection.
- Added topology information to Intrabuilding backbone cross-connect section.
- Added voice jumper cross-connect guidelines to Intrabuilding backbone cross-connect section.
- Added Fiber Optic Jumper section.
- Added Data circuits cross-connect section.
- Changed "Wiring Distances" section to be "Intrabuilding Backbone cabling lengths".

- Added cable length chart for copper and fiber optics.
- Added cross-connect equipment length.
- Added Fiber maintenance loop section.
- Added Intrabuilding backbone cable bend radius section.
- Added specification for ANSI/TIA/EIA 568A and 568B under Horizontal Cabling section.
- Changed minimum station outlet for voice to be category 3 or higher.
- Added to data outlet configuration performance guidelines for category 5E jacks.
- Changed CATV horizontal cable from RG59 to RG11.
- Added conduit/cable tray requirement for CATV cable installation.
- Added conduit/cable tray requirement for fiber optic multi-mode and single mode horizontal cable.
- Removed section on jumper wires for data.
- Changed “Horizontal lengths” section to “Horizontal cabling system design considerations”.
- Added horizontal cabling link and channel lengths section.
- Added cabling practices (installation) section.
- Added horizontal cable slack section.
- Added code requirements to Terminations section.
- Added Wall and relay rack layout considerations section.
- Made changes to cable routing section including layout and use of cable management devices.
- Added voice riser termination device S66M1 blocks.
- Added use of data patch panel as termination device for data copper riser cables.
- Added CATV riser termination section.
- Changed horizontal outlet configuration to single gang faceplate with a minimum of four ports.
- Added removed Ortronics IMO reference from outlet section.
- Added new voice jack insert termination configuration section.
- Added new data jack insert termination configuration section.
- Changed CATV jack insert to include snap in insert.
- Changed “optional outlets” section to “additional jack inserts terminations”.
- Added customer option for additional jacks to “additional insert terminations section”.
- Added ADA requirements to terminations section.
- Added “horizontal voice cable termination” section.
- Changed termination recommendations for voice station cables.
- Added horizontal data cable termination section.
- Removed Krone 66 type block as termination device for data horizontal cables.
- Added CATV horizontal cable termination section.
- Added fiber horizontal termination section.

- Added drip loops, use of D rings and jumper lengths for voice cross connects in horizontal cross-connect section.
 - Added horizontal data circuits cross connects section.
 - Added horizontal fiber jumper section.
 - Changed cross-connect color coding figure in labeling section.
 - Added backbone riser terminal labeling.
 - Added labeling guidelines for patch panels and voice, data and catv outlets.
 - Changed horizontal outlet numbering scheme.
 - Added "handwritten labels are not recommended".
 - Added "Telecommunications Grounding and Bonding" section.
 - Added OTC "Recognized Hardware, Media and termination Materials" section.
 - Added "has developed both a ten year and twenty year plan" to section on campus master plan.
 - Added 18 new applicable codes and standards to the "Applicable codes and standards" section. Added "Glossary of terms" section.
 - Added Illustrations section.
 - Added Illustrations 1 thru 7.
- 2.1 7/25/00
- I.D.1.a.9 - Added 4"W x 16"L x 3"D (Raco 956 or Equiv) to Horizontal pathway.
 - I.D.1.a.10 - Added flush cover to 4"x4" wall box (Raco 787 or Equiv).
 - I.D.1.a.11 - Changed wall box for paytelephones, wall phones etc to 4"x4".
 - Added B/C grade plywood as an option for backboard material.
 - I.D.2.f - Added Card security / card swipe conduit requirement.
 - Removed Thin and thick wire Ethernet from media section.
 - Changed Prestolite to Krone in recommended materials section.
 - Changed Siecor to Corning in recommended materials section.
- 2.1 10/18/00
- Added minimum size opening for access panels below pull boxes in hardcoat ceilings. D.1.a.9
- 2.1 02/21/01
- Change to define entrance conduit requirements. A total of 2w4 (2-4") conduits as a minimum into any building under 10,000 square ft usable floor space. Conduit duct banks entering buildings of over 10,000 square feet shall be sized with the assistance of the Office of Telecommunications.
- 2.2 03/30/01
- Changes made to various areas to clarify conduit installation design criteria including the attachment to walls, turning down conduits to TBB, floor height, etc. To eliminate confusion the term closet was replaced with room.
- 2.2a 07/24/01
- Change Section I.B. MANHOLES from "round lids no less than 32 inches" to read "round lids with a diameter of 32 1/2 inches."
- 2.2a 08/22/01
- Change Section I.B. MANHOLES from " New manholes shall be 8'x8'x8' deep octagon" to " New manholes shall be 8'x8'x7' deep octagon".
- 2.2a 10/25/01
- Change Section III.C.4.a.2 (Horizontal cabling practices) to read " Do not cinch cable bundles tightly. Velcro straps should be used on all data cable

bundles and not cable ties to avoid overtightening and deformation of the cable jacket. Avoid deforming the jacket.

- 2.2b 8/24/02 - Addition to Section I.D.2.g “Floor Outlets – Floor outlets shall be multiservice recessed floor boxes, Wiremold/Walker part number RFB4-SS with RFB-4TKO-SS internal communications brackets. Any equivalent box shall be approved in advance by the FSU Office of Telecommunications.”
- 2.2b 11/5/02 - Added specifications and restructured Horizontal Pathway Sections D.1.b Secondary Design Choice - Ceiling Raceway and D.1.c.Third Design Choice – Zone Conduit.
- 2.2b 2/14/03 - Restructured Horizontal Pathway Sections D.1.b Secondary Design Choice -. Zone Conduit. Third Design Choice –Ceiling Raceway and D.1.c
- 2.2b 2/14/03 - Misc corrections. New description of clearances in Communications rooms.
- 2.2c 7/8/03 - Sec I.D.1.a Horizontal Pathway, added specifications of catv conduit to be $\frac{3}{4}$ ”.
- 2.2c 7/8/03 - Sec II.B Power, Added A/C outlet to be installed in each comm. Room on end of Relay Rack.
- 2.2c 7/8/03 - Sec III Approved Media, changed OSP entrance Fiber to the standard of 12 single mode and 6 multimode 50 micron fibers.
- 2.2c 7/8/03 - Added new labeling standard 606A
- 2.2d 2/5/04 - Add description of Code Blue installation requirements.
- 2.2d 4/27/04 - I.D.2 Added Access / Security Door Raceway requirements
- 2.2e 6/18/04 - IV.C.1.b.1a Addition of angled faceplates as a standard in all new residential halls
- 2.2e 8/3/04 - Added specification for inside Code Blue Emergency phones.
- 2.2e 9/30/04 - II.D.2 Added electrical specifications for Access systems.
- 2.2e 11/10/04 - Changed station outlet fiber option standard from 62.5/125 to 50/125 micron SX+.
- 2.2e 11/10/04 - Riser standard for fiber riser was changed from 62.5/125 to 50/125 micron SX+.
- 2.2e 11/10/04 - Removed MT-RJ jumpers and changed jumper standard to 50/125 micron, SX+.

- 2.2e 11/10/04 - Added Standards for fiber connector panels.
- 2.2e 11/10/04 - Added fusion splicing as standard for termination of fiber.
- 2.2e 11/10/04 - Add Sub-Section B – “OSP Termination” under Termination Section.
- 2.2e 11/10/04 - Added new standard Fiber materials and hardware to materials List.
- 2.2f 04/11/05 - Added New elevator telephone template.
- 2.2g 07/27/05 - Changed Sec II Telecom Rooms requirement for 2 – 4” conduits between telecom rooms on same floor to 1 – 4” minimum.
- 2.2g 05/22/06 - Changed Emergency Blue Light Phones from Code Blue to Talk-A-Phone

NOTE:

Deleted: ¶

- 1) Versions 1.4, 1.5, 1.5 (a) and 1.6 were made with input from the FSU Networking Committee
- 2) Revision 1.6 (c) was made with input from the IRM Office at FSU
- 3) Version 1.7 will include a glossary of terms



INTRODUCTION TO....

FSU'S TELECOMMUNICATIONS INFRASTRUCTURE STANDARD

The Office of Telecommunications (OTC) is proud to release the latest update to the FSU Telecommunications Infrastructure Standard. **Release 2.2**. A Telecommunications Infrastructure Standard for FSU has been in existence for over (13) years. During that time it has had over (16) revision. The OTC in conjunction with FSU's IMR Manager, Facilities Planning and Construction, Academic Computing & Networking Services, the Campus Networking Committee and Office of Technology Integration has evolved and developed the Florida State University Telecommunications Infrastructure Standard.

The mission of the Office of Telecommunications as clearly outlined in the Finance and Administration Business handbook is for the OTC to be the "University's coordinator and provider of telecommunications transport services on and off of campus. This includes, but is not limited to all infrastructure of copper, coax and fiber wiring within and between campus, calling features, CATV, consulting and operator services, local dial tone, directed moves, emergency telephones, frequency coordination, outside plant, pay telephones, telephone instrumentation, voice and video conferencing, wireless technologies, voice mail, long distance services, paging, security and access, and 2-way radio."

Additionally, **"The OTC has the responsibility of design, development, approval, installation, maintenance and management of telecommunications wiring and infrastructure in all FSU owned and leased buildings and properties. This would include but is not limited to voice, video and data infrastructure with fiber, copper or coaxial cabling.** This also includes telecommunication rooms, raceways, conduit systems, duct banks and the campus telecommunications manhole system. Such responsibility implies a first right of refusal by the OTC on all wiring design, development, approval, installation, maintenance and management."

The OTC works closely with many departments at FSU to assure that this mandate is carried out. We do this in two main ways.

- a. The OTC in conjunction with Campus Design and Campus Planning review design documents in several phases of completion to assure their compliance to local and national standards and codes. Typically design development, conceptual drawing, 50% and 100% drawing are all reviewed and input on changes are implemented throughout the process.
- b. Working with design professionals, departments and electrical engineers they have ready access to this standard to reference when questions or conflicts should arise in

any construction or renovation process. Through close interaction during the design of new projects, the review of renovation projects and future campus planning the entire design team assures that uniform, cost effective and high quality telecommunications infrastructure are consistently installed.

We are pleased to have this valuable tool available to you as you design telecommunications infrastructure here at FSU. Please feel free to contact our office when needs arise. Our goal is to be available to assist you at any time before or during the decision making process.

Thank You

I. CONDUIT AND MANHOLE SYSTEM

A. SERVICE ENTRANCE

The Service entrance is the route by which Telecommunication services/lines enter a building. There are three types of service entrances:

- Underground Entrance - buried conduit (FSU responsibility)
- Buried Entrance - cable buried in a trench (Service Provider responsibility)
- Aerial Entrance - cable drop from a pole to a building. (Service Provider responsibility)

Service entrances shall terminate at the main telecommunications room / terminal room location of the building; usually on the ground floor or basement.

1. Underground Entrance – The following recommendations are made for underground entrances:
 - a. The recommended size for conduit used in an underground entrance is 4 inches in diameter. A spare conduit of equal size is recommended, thus giving a total of 2w4 (2-4") conduits as a minimum into any building under 10,000 square ft usable floor space. Conduit duct banks entering buildings of over 10,000 square feet shall be sized with the assistance of the Office of Telecommunications.
 - b. Conduit must be buried at a minimum depth of no less than 36 inches (or to meet local codes) and encased in concrete rated at 2,500 psi. For conduit that will be placed under a road use 3,500 psi rated concrete. Other special situations may require the use of stronger or a lighter 10 to 1 mixture. These exceptions shall be approved by the OTC design professional. To minimize any chance of accidental dig-up, place a plastic warning tape a minimum of 18 inches below the surface and directly above the conduit. Tape will be provided by the Office of Telecommunications on request. It is recommended that Telecommunications conduit not to be placed in joint trenches with other utilities. When this is necessary though, the design professional shall contact the Office of Telecommunications for design and coordination. Other utilities shall not be placed in telecommunications ducts. A # 6 AWG copper ground wire shall run parallel to the conduit within the concrete encasement. Design of underground entrance should be coordinated with the OTC. (NOTE: Telecommunications conduit shall not be poured and encased in the same concrete as the campus high voltage (typical - 5kv-12kv) electrical conduits system. A minimum of 18" of fill shall be between the two facilities.)
 - c. Entrance conduit must not include more than two 90 degree bends without a pull box, hand-hole or manhole. Bends must be sweeping bends with a radius not less than 10 times the inside diameter of the four inch conduit. NO LBs.

- d. Conduit shall be corrosive – resistant of one of the following type:
 - Rigid galvanized metal
 - Plastic polyvinyl chloride (PVC) Schedule 40 or equivalent.
- e. Conduits should be clean, dry, unobstructed, labeled for identification, reamed and fitted with bushings.
- f. Conduits shall have a pull cord having a metallic member (tone tape) with a minimum test rating of 200 lbs pulling strength in each conduit. Reference: Arnco DL WP12LC Tone Tape or equivalent.
- g. When terminating entrance conduit within a building, design conduits entering from:
 - Below grade- to extend 4 inches above the finished floor.
 - Through ceiling - to extend to 8 1/2 feet above finished floor.
 - Through walls - install with sweeps not less than 10 times the inside diameter of the conduit to turn conduit down on wall to extend to 8 1/2 Feet above finished floor or at a point above the eight (8) foot tall TBB.
- h. Seal the inside-the-building end of all conduits to prevent rodents, noxious gases and water from entering building.
- i. All entrance conduits shall be securely fastened to the building so they can withstand a typical placing operation.
- j. Telecommunications conduits shall be used for telecommunications cables only and shall not be used for joint use with electrical utilities.

Table 1 - Recommended Quantity of Service Entrance Conduits

<u>Gross Building Floor Area (x 100 Ft. Sq.)</u>	<u>No. Of Conduits (includes spare)</u>
0 - 20	2 (minimum)
20 - 100	4
100 - 500	6
500 - 1000	8
1000 - over	size accordingly

A dual (duplicate - two diverse routes) service entrance is recommended for buildings which provide crucial services such as critical research facilities, hospitals, police stations, fire stations and other similar buildings.

2. Buried Entrance - This method is discouraged. Temporary service to a building is an acceptable justification for buried cable. Design for buried cable should be

coordinated with OTC. Refer to Section III, Media for additional information on buried cable.

3. Aerial Entrance - This method is discouraged. Temporary service to a building is an acceptable justification or installation of cable into an existing facility when underground entrance is too expensive or would disturb vegetation. Pole sizes, clearances and cable sizes should allow for future growth and flexibility and meet. The installation of aerial cable entrance facilities and associated supporting structures should be coordinated with the OTC. Refer to Section III, Media for additional information on aerial cable.

Design professionals and contractors shall contact the OTC engineering group project manager for evaluation and determination of exceptions to design guidelines for entrance conduit.

B. MANHOLES

FSU has an extensive network of telecommunication manholes throughout campus. The facility design professional should assure all renovations and new construction projects connect to this system where needed. Any new manhole number assignment shall be coordinated through the OTC.

New manholes shall be 8'x8'x7' deep octagon with round lids with a diameter of 32 1/2 inches. Hand holes (small manholes) are not acceptable unless approved by the OTC. No square lids are permitted. Lids should have pull-slots for easy removal, traffic rated, and labeled "TELECOMMUNICATIONS OR TELEPHONE. Grounding rods should be included in the design of all manholes. The distance between manholes shall be no more than 300 feet if a direct path is possible and no 90 degree bends are used. For every 90 degree bend used between manholes subtract 50 feet. No more than two 90 degree bends shall be installed between any two pulling points.

Manhole interior hardware must be galvanized. Manholes should be equipped with

- Bonding inserts and struts for racking.
- Pulling Eyes at least 7/8" in diameter.
- A floor sump of at least 8" in diameter.

The strength of concrete used for manholes shall be at least 3,500 PSI.

C. OUTSIDE PLANT CONDUIT (INTER-BUILDING DUCTBANKS)

The University has a system of underground ductbanks throughout its property used for providing telecommunications services to University buildings. The use of conduit space in the Telecommunications Ductbanks shall be managed by the Office of Telecommunications.

1. Outside Plant Conduit Duckbanks shall meet the following Requirements:
 - a. The recommended size for conduit used between manholes is 4 inches in diameter. Ductbanks connecting Manholes shall consist of a minimum of 8 (8) four inch (4") conduits 8w4 (8-4").
 - b. Conduit must be buried at a minimum depth of 36 inches (or to meet local codes) and encased in concrete rated at 2,500 psi. For conduit that will be placed under a road use 3,500 psi rated concrete. Other special situations may require the use of stronger or a lighter 10 to 1 mixture. These exceptions shall be approved by the OTC design professional. To minimize any chance of accidental dig-up, place a plastic warning tape a minimum of 18 inches below the surface and directly above the conduit. Tape will be provided by the Office of Telecommunications on request. It is recommended that Telecommunications conduit not to be placed in joint trenches with other utilities. When this is necessary though, the design professional shall contact the Office of Telecommunications for design and coordination. Other utilities shall not be placed in telecommunications ducts.
 - c. Do not include more than two 90 degree bends. Bends must be long sweeping bends with a radius not less than 10 times the diameter of the four inch conduit. LB's shall not be used.
 - d. Conduit shall be corrosive – resistant of one of the following type:
 - Rigid galvanized metal
 - Plastic polyvinal chloride (PVC) Schedule 40 or equivalent.
 - e. A # 6 AWG copper ground wire shall run parallel to the conduit within the concrete encasement. Design of underground entrance should be coordinated with the OTC. NOTE: Telecommunications conduit shall not be poured and encased in the same concrete as the campus high voltage (typical- 5kv-12kv) electrical conduits system. A minimum of 18" of fill shall be between the two facilities.
 - f. Conduits should be clean, dry, unobstructed, capped for protection, labeled for identification reamed and fitted with bushings.
 - g. Provide a pull cord having a metallic member (tone tape) with a minimum test rating of 200 lbs pulling strength in each conduit. Reference: Arnco DL WP12LC Tone Tape or equivalent.
2. Special Outside Plant Applications-
 - a. Blue Light Emergency BLT towers Phones, Coin operated Pay-telephones, other emergency and outside telephones – Emergency phones located outside require the following:

Provide 2" PVC schedule 40 conduit, buried a minimum of 30" with marker tape placed 18" below the surface and directly above the conduit. The conduit shall be terminated in the nearest manhole, building telephone equipment room or apparatus room. (closest service location). Conduit runs shall not exceed 200 feet without a handhole or pull box and shall contain no more than two 90 degree bends per 200 feet, excluding those bends within 5 feet of the pull box. A pullbox shall be provided within 10 feet of the BLT where the 2" conduit will terminate. A 1" conduit shall be installed from this point into the BLT. Conduit and pull boxes shall be for telecommunications cables only and not for joint use with electrical or other utilities. Install a nylon pull cord with a minimum test rating of 200lb pulling tension. Reference: Arnco DL WP12LC Tone Tape or equivalent.

- b. Handholes / Pull-Boxes - Where handholes / pull boxes are used, they are not to be used for termination or splice boxes under any circumstances. Install handholes / pull-boxes in easily accessible locations, preferably not in parking or traffic areas. Installation should be at grade. Boxes should be provided with a weather-proof door/panel or cover arranged for access from the top. Avoid installation adjacent to sprinkler discharge. Conduits should be installed with sweeps. Do not use a pull-box in lieu of a bend. Telecom Pull boxes **SHALL NOT** be used by other utilities.

D. HORIZONTAL PATHWAY DISTRIBUTION SYSTEMS (INTRA BUILDING)

Telecommunication wiring distribution may be made through various ceiling distribution systems, especially where suspended ceilings are utilized.

1. HORIZONTAL CONDUIT DESIGN RECOMMENDATIONS

a. Preferred Design Method

Conduit System – Each workstation Voice / Data outlet box shall be installed using one (1") inch conduit. CATV outlets shall be installed using three quarter (3/4") inch conduit. All conduits shall be home-run or routed directly to the main telecommunications room (MTC) or telecommunications room (TC) of the same floor. (Physical Star Topology). Conduit shall be EMT with screw or compression fittings. Flex conduit shall not be used in buildings for telecommunications cabling. Horizontal conduits designated for outlets shall not feed floor to floor or be daisy chained from outlet to outlet.

Because the facilities conduit distribution system, once installed, is of "fixed capacity", it is often cost effective to install sufficient distribution conduits to accommodate potential changes and growth.

- 1) The total individual conduit length including pull boxes used for telecommunications systems should not be longer than 250 feet.

- 2) Conduit runs should take the most direct path possible, following parallel lines of the building.
- 3) There should be no conduit continuous sections longer than 100 feet. For sections that are longer than 100 feet, insert pull boxes so that no segment between pull boxes exceeds the 100 foot limit.
- 4) There should be no more than two 90 degree bends between pull boxes.

If a conduit run requires more than two 90 degree bends provide a pull box between sections with two bends or less or use the next larger size of conduit.

A third bend may be acceptable in a pull section without de-rating the conduit's capacity if:

- The run is not longer than 33 feet.
- The conduit size is increased to the next trade size, or
- One of the bends is located within 12 inches of the end of the cable feed end.

- 5) Conduit bend radii shall be as specified in the current edition of the National Electrical Code for conductors without lead sheath. Field and machine bent radii are acceptable.
- 6) Provide a pull cord with a minimum test rating of 200 lbs pulling strength in each conduit. Greenlee Jetline, Part number 430 or equivalent.
- 7) Conduits should be clean, dry, unobstructed, labeled for identification, reamed and fitted with bushings.
- 8) Terminate conduits through the structural floor in the telecommunications rooms three (3) inches above the floor surface. For conduits entering from the ceiling conduits should be installed to turn down and extend to 8 1/2 feet above finished floor in the Telecommunications rooms or equipment rooms. All conduits shall be dressed at the same level and installed with rigid conduit straps to the wall.
- 9) Pull-Boxes - Pull boxes shall be a minimum of 4"W x 16"L x 3"D D (Raco 956 or Equiv) for a single one (1) inch conduit. For each additional conduit two (2) inches should be added to the width of the box. Four (4) inch square outlet boxes shall not be considered for pull-boxes under any circumstances. Pull Boxes are not to be used for termination or splice boxes under any circumstances. Install pull-boxes in easily accessible locations, preferably above suspended ceiling. In the case of hardcoat ceilings, an access panel shall be installed in the ceiling directly beneath any pull boxes. The opening shall be a minimum of 24" x 24" to allow for access. Pull Boxes should be provided

with a suitable hinged panel or cover arranged for access from the bottom. Conduits should be arranged to allow a straight pull through the box with no bends. Do not use a pull-box in lieu of a bend. Telecom Pull boxes shall not be used by other utilities.

NOTE: Designs that require pull boxes be mounted more than 10 feet above the floor shall first be approved by the OTC.

- 10) Telecommunications Workstation Outlet Boxes - All standard telecommunications wall mounted workstation outlet boxes installed in dry wall, plaster or concrete block shall be four (4) inches square by at least 2 1/4" deep made by Steel City or equivalent. All boxes shall be trimmed out, allowing for a clear and unobstructed 4" opening. Provide all boxes with flush cover (Raco 787 or equiv). Boxes should be installed 15 inches above finished floor or the same height as electrical outlets at the workstation. Do not install outlet boxes back to back to serve adjacent rooms. Boxes should be offset to avoid compromise of the effectiveness of the sound barrier. Boxes shall not be installed and connected by the same 1" conduit in a daisy chain method or from floor to floor.
- 11) Outlet boxes for wall instruments, payphones and other special applications shall be 4"W x 4"H x at least 2 1/4"D. These boxes should be mounted at 48" above the finished floor unless obstructed. Installation of outlets where obstructions exist shall meet all ADA requirements for clearance as specified below.

b. Secondary Design Choice

Zoned Conduit System - Zoned conduit systems are recommended for areas with a high density of outlets such as computer labs or if space above a ceiling is not available or wall penetrations must be kept to a minimum. For office areas provide a minimum of one two-inch conduit for each 500 square feet of usable office area. Provide three one-inch outlet conduits for each two-inch conduit for telephone outlets within the zone. All two-inch zoned conduits shall be metallic and shall be run from the equipment room or satellite room to the zone where the conduit is terminated at a pull box. One-inch conduits shall also be terminated in the pull box. Sizing of conduits for high density areas such as computer labs must be individually designed based on outlet configurations. The selection, design and installation of Zoned Conduit Systems should be pre-approved and coordinated with the Office of Telecommunications. Pull-Boxes for a single 2" conduit and 1" conduit shall be at a minimum 8'Wx36"Lx4"D. For each additional 2" conduit add 5"W. Add 2"W for each additional 1" conduit.

High speed twisted copper data cables are highly susceptible to degradation of operation due to any change in physical characteristics, i.e. flattening of cable, etc. Devices that do not provide continual support of the cables are not

recommended. The use of J-Hooks, D-rings, cable hangers and other devices for horizontal distribution are not recommended. Installation in ceiling spaces which serve as return air plenums shall be installed within closed conduit unless the conductor insulation and jacket material is Teflon (DuPont), Halar (Allied Chemical), Kynar (Pennwalt Corp.), Kaptan (DuPont), or approved equivalent, and the wire and cable has received UL classification in accordance with the current edition of the National Electrical Code.

c. Third Design Choice

Ceiling Raceways (Cable Tray) - Ceiling raceway (cable tray) systems may be used, but are not recommended due to the potential for long term maintenance issues, increased costs of plenum rated materials, increased installation labor costs, wire damage and fire code violations. If raceways are located in a ceiling that is a return air plenum, the wire and cable used shall be specified as return air plenum wiring.

- 1). Ceiling raceway will be Homaco Tubular Runway Ladder Style Cable Tray or equivalent, Part Number TRXX-XX. No less than TRXX-12 (12" Wide) runway should be used in hallways adjacent to Communications Rooms. Raceway sizing and installation shall be made based on manufacturer recommendations. Cable tray capacity is 40% to 50% as determined by the static load capacity of the tray and length of the support span and is limited by ANSI/NFPA 70, Section 318.
- 2). Supports shall be installed no more than five (5) feet apart and within two (2) feet of any fitting.
- 3). Tray shall be installed with six (6) inch cable fence on both sides of the tray placed at a spacing of every other cross slant.
- 4). Transition pans, curved runways and horizontal radius runway sections shall be used when space allows to avoid sharp turns that may cause damage to cable.
- 5). Ceiling raceway shall be readily accessible and placed in ceilings that utilize removable tile. If transition of hardcoat ceiling is required access hatches of a minimum of 24" x 24" should be installed every 15 feet.
- 6). Ceiling raceways shall be installed in ceilings of hallways and shall avoid passing over office spaces, offices, classrooms and other occupied spaces.
- 7). There shall be no other structures run directly through the ceiling raceways. Such items as sprinkler heads and HVAC ductwork shall not drop through ceiling raceways. When designing the layout of horizontal pathways in the ceiling spaces, ensure that other building components (e.g. lighting fixtures, structural supports, air ducts) do not restrict access.

- 8) It is strongly recommended that Telecommunications Raceways not be shared by power cables.
- 9) Cable Trays shall have adequate clearance above the tray for installation of cabling and to withstand pulling cables and below the tray for access during installation. Raceways should be installed allowing a minimum of:
 - Three (3) inches of clear vertical space above the ceiling tiles to ensure accessibility to the tray. When sufficient space is available above raceway provide up to six (6) inches between tray and ceiling tiles.
 - Twelve (12) inches of clear vertical space above the tray.
- 10) Because cable installed in tray is susceptible to electromagnetic interference (EMI). Raceway should be routed to avoid electrical interference. Avoid crossing or running tray parallel to fluorescent lighting fixtures and electrical devices that produce EMI. Always keep a minimum of four (4) inches clearance from these devices. All metallic cable trays must be grounded, but may also be used as a ground conductor. Tray bonding and grounding should follow all applicable building and electrical codes including ANSI/NFPA 70, section 318-3 (c).
- 11) Ceiling raceway shall be used in conjunction with 1" conduits from the outlet box and run to the ceiling raceway. Conduits should extend all of the way to the tray. Conduit should be properly cleaned, a bushing installed and bonded to the cable tray.
- 12) The design and installation of Ceiling Raceway Systems shall be installed to meet ANSI/NFPA70, Article 318 – Cable Trays, and all applicable national, state and local codes. The selection, design and installation of Ceiling Raceways should be pre-approved and coordinated with the Office of Telecommunications.

2. SPECIAL USE CONSIDERATIONS

Special use considerations - Some specific types of areas and uses differ from "office/conference room" type space as mentioned above. Therefore, these areas should be addressed in the list below:

- a. Classrooms - should have at least one outlet on every wall. This outlet would include the minimum service as described in the media section of this standard and also CATV as a standard jack (i.e.-voice, data, CATV minimum). The design professional should consult with the department and the OTC on a case by case basis to assure that any special needs are met.
- b. Laboratories - are unique and at times may require more or less telecommunications resources. Therefore, the design professional should consult

with the department and the OTC on a case by case basis to assure that needs are met.

- c. Modular Office/Open Areas- are unique and at times may require special modular telecommunications hardware. Special conduit and termination boxes may also be required. Therefore, the design professional should consult with the department and the OTC on a case by case basis to assure that needs are met.
- d. Fire/Burglar Alarm Panels - A dedicated 3/4" conduit shall be run from each fire and burglar alarm panel to the telecommunications room horizontal cross-connect. This is required to UL approve systems. Please refer to the latest revision of NEC code available.
- e. Elevators - A dedicated 1" homerun conduit shall be run from the telecommunications room to the elevator equipment room and connected to a 2"W x 3"H x 2 1/2"D single gang box adjacent to the elevator equipment. Elevator instruments are normally provided by the OTC. The design professional should consult with the OTC concerning the university instrument of choice. See Fig 9 for telephone template to be used in cab. Elevator phones to be provided by FSU OTC.
- f. Access / Security Systems –
 - 1) Security Sensors / Camera locations – When these devices are required a 1" conduit shall be provided with a 4" x 4" x 21/2" j-box at the location of the device. The conduit shall be homerun from the telecommunications room.
 - 2) Access / Security Door Raceway requirements – each ground floor exterior door and other specified doors shall be provided with a 12" x 12" j-box and a homerun 1" conduit run to the telecom room. Provide the following:
 - a) From the J-box provide a 1/2" conduit to the door contacts in the header (2 for double doors).
 - b) From the J-box provide a 3/4" conduit to the card reader or pin pad location. Terminate in a single gang box.
 - c) From the J-box provide a 1/2" conduit to the strike side in the door frame (for electric strike.)
 - d) Provide a 1/2" conduit to the hinge side in the door from power supply provided with the electrified panic devices when used. From the J-box provide a 1/2" conduit to the power supply.
 - e) Holes shall be drilled in the door header frame for wiring the door contacts.
 - f) Provide a 3/4" conduit from the request to exit box to the J-Box. The request to Exit box shall be a standard single gang outlet box

mounted sideways 1 foot above the door frame inside the room being exited.

FSU OTC maintains examples of the most current access control door configurations at http://www.otc.fsu.edu/Architecture_PDFs/

3) Typical Door Requirements –

- a) Ground Floor perimeter Doors – Card Reader, Door Contacts and Request to Exit.
- b) Ground Floor Stairs door – Door Contact, Request to Exit.
- c) ACNS Classroom Doors – Card Reader, Door Contact, Motion Detector.

4) Electrical Requirements –

- a) Panels and centralized equipment shall be located in the telecommunications rooms and shall be provided with 120 volt A/C, 20 amp dedicated circuits and shall be on the building emergency power in the case of power outages.
 - b) Power provided to doors for operation of electrical devices shall be provided 120 volt A/C, 20 amp dedicated circuits and shall be wired to the building emergency power.
- g. Floor Outlets – Floor outlets shall be multi-service recessed floor boxes, Wiremold/Walker part number RFB4-SS with RFB-4TKO-SS internal communications brackets. Any equivalent box shall be approved in advance by the FSU Office of Telecommunications.
- h. Internal Emergency Phones – Emergency phones located inside require the following:
- A dedicated 1”” homerun conduit shall be run from the telecommunications room for the voice line to a FME – Flush Mount Enclosure box where the phone is to be installed. **See ADA requirements for height of the enclosure.** A 120 volt A/C, 20 amp dedicated circuit shall be provided to a single gang outlet mounted in the bottom of the FME Box. The design professional should consult with the OTC concerning the university instrument of choice or any required signaling devices.

3. ADA Requirements - Outlets in public locations that will require access by the handicapped (i.e. payphones, public phones, etc) have special height and reach requirements for their installation in terms of the “Highest Operable Mechanism”. All outlet boxes for these shall meet the following guidelines:

Side Reach – Maximum of 54 inches. If side reach occurs over an obstruction 24” wide and 34” high, the maximum allowed side reach is 46 inches.

Forward Reach – Maximum of 48 inches. If the forward reach occurs over an obstruction 20” to 25”, the maximum height must be 44 inches.

Shall provided roll up access for handicap appliances.

E. MISCELLANEOUS DISTRIBUTION SYSTEMS

Depending on the type building and construction materials, there are other methods of distribution that may be used.

1. Perimeter Distribution/Wire Mold - A raceway system may be used for perimeter distribution. The raceway system can be mounted at desk height or can be recessed into the base of the wall to form a baseboard.
2. Open Wiring - Open wiring may be used in wood frame construction in wall, ceiling, and floor cavities.
3. Conduits run in slabs or other concrete structures shall be PCV Schedule 40 or Rigid galvanized metal. The minimum size for horizontal cabling is one (1) inch.

F. INTRABUILDING BACKBONE RISER CONDUIT SYSTEM

A vertical telecommunications conduit riser system shall be provided for bringing telecommunication cables from the Main Telecommunications room MDF to the various floors of the building. As a design guideline, the vertical cable riser system should use a series of vertically aligned 4” sleeves in each floor beginning in the ceiling of the telecommunication room in the basement and ending in the floor of the telecommunication room of the uppermost floor.

RISER CONDUIT DESIGN RECOMMENDATIONS

1. The vertically aligned 4” sleeves should be located in the vertically aligned (stacked) telecommunications rooms on each floor. Riser conduits or sleeves entering through the floor shall extend 3 inches above finished floor at the wall. Riser conduits or sleeves extending down from the ceiling shall extend to 8 1/2 feet above finished floor. If turns are required they shall meet the bend radii already specified in this document. All conduit ends shall be dressed at the same level and installed with rigid conduit straps or equivalent to the wall. Design professionals and installation contractors shall contact the OTC project manager to address exceptions due to structural conflicts.

2. All sleeves and Riser Conduit shall be 4 inches in diameter.
3. Sleeves should not be place in the middle of the Telecommunications room floor, but placed next to the wall that has plywood attached, preferably starting in the left corner when entering the door.
4. Construct all sleeves to conform with the National Electrical Code and local Fire Codes.
5. All Sleeves should extend 3 inches above the finished floor level.
6. All sleeves should be clean, dry, unobstructed, labeled for identification, reamed and fitted with bushings.
7. After the riser cable has been installed, all unused sleeves shall be fire stopped.
8. The quantity of sleeves depends upon the building's usable floor space serviced by the sleeves. The quantity and size of the sleeves shall be applicable to conduit when vertical stacking of rooms is not possible. Table 2 shows the recommended quantity of sleeves to be provided, and typical vertical riser arrangements, and including one spare for emergency use and one for coax or fiber optic use.

Table 2

Usable Building Floor Area (x 100 Ft. Sq.)	Recommended Sleeve Quantities No. Of Sleeves
0 - 129	4 (minimum)
130 - 259	6
260 - 389	8
390 - 520	10

II. TELECOMMUNICATIONS ROOMS / EQUIPMENT ROOMS

A. DEFINITION

This section identifies 3 (three) physical spaces within a building that are critical to the proper management and transport of telecommunications (voice, video, data) services. They are the Main Telecommunications Room (MTC), Telecommunications Rooms (TC) and the Customer Premise Equipment (CPE) Room. Any of these rooms may be referred to as a Telecom Room.

The primary telecommunications room for the entire building is the Main Telecommunications Room (MTC). This room serves as the entrance facility for the building where all outside plant conduits terminate. It houses the Main Distribution Frame (MDF), where the service entrance cables terminate and interface with the intra-building backbone distribution cabling system and to the horizontal cross-connect and cabling serving that floor. The MDF is considered the point where the regulated telephone company will install the building entrance protectors. This point of interface is called the demarcation point. The demarcation point is where the cabling responsibility of the Service Provider (regulated telephone company) ends and where the cabling and equipment responsibility of the University OTC begins.

Other wiring rooms/rooms within a building are referred to as Telecommunications Rooms (TC). TC's are "floor serving". There shall be a minimum of one TC per floor. A TC is not required on the same floor as an MTC unless needed due to cable length requirements. It is recommended that multiple TC's should be provided on the same floor if usable floor space exceeds 10,000 sq ft. or the conduit length between the horizontal cross-connect in the TC and any Telecommunication outlets being served would exceed 270 total feet. Maximum allowed length of horizontal cable installed to outlets must not exceed 295 feet. Pathway length should be kept to a maximum of 270 feet to accommodate the cable length.

The MTC and TC rooms contain the intermediate distribution frames (IDF's) which include the terminations for the backbone cables in the riser system coming from the MDF and the terminations for the horizontal cabling and cross connects on the floor served. In addition to cable terminations and cross connects in these rooms they may in some cases serve as an equipment room for data, video and other equipment.

The Main Telecommunications room MTC and TC rooms are not to be shared facilities for other services and therefore should not house electrical equipment, plumbing, janitor sinks, or to be used as a storage area. HVAC Duct other than that serving the room, electrical conduits for other areas, sprinkler system piping, drain pipes, steam pipes, chilled water pipes, or any other systems should not be routed through the interior of the MTC, TC or CPE rooms. Any other conceived use for the telecommunications rooms that don't follow the intended use of telecommunications is not permitted.

The design professional shall make provisions for separate CPE room(s) within newly designed and renovated buildings. This room will house private departmental / customer computer and server equipment. Such rooms shall be contiguous to the MTC and TC rooms. If this is not possible, these areas shall be connected via a series of 4" conduits. If the rooms can not be contiguous, the designs must be approved by the OTC

B. REQUIREMENTS

1. MTC / TC Room(s) - shall include the following:

- a. Wall Linings - All walls should be finished, i.e. sheet-rock/painted, and lined with 3/4 inch thick, A/C or B/C Grade Plywood backboard, 8 foot high by 4 foot wide and affixed in such a manner that it will support the weight of the cable, terminals, and other equipment. This allows for coverage of the entire area on which connecting hardware and cable management hardware may be mounted. The plywood should extend around the entire room, corner to corner on every wall. Smooth side shall be installed out. The plywood backboard shall be void free and treated with two coats of fire retardant paint materials. Use flush hardware and supports to mount plywood. The strength and placement of mounting hardware shall be sufficient to handle the total anticipated load (static and dynamic) and mounting of cabling components. The placement of the plywood backboard shall be on top of the wall covering, i.e. sheet-rock, etc. and is not a substitute for the wall covering.
- b. Lighting recommendations -
- A light intensity level of 70 foot candles minimum should be provided measured at 3.3 feet from the finished floor.
 - Do not use dimmer switches.
 - Locate light fixtures a minimum of 8', 6" above the finished floor.
 - Emergency lighting is recommended if available.
- c. Power –
- Provide at least one dedicated 120 VAC, 20 amp (non-switchable) quad receptacle on each wall.
 - Locate receptacles at least 6 inches above finished floor.
 - Receptacles must not be controlled by wall switches.
 - Provide one (1) dedicated 120 VAC, 20 amp (non-switched) outlet to be installed at the top and end of the End Relay Rack in each communications room. Placement of the relay racks are done by the FSU Office of Telecommunications. The Electrical Contractor shall coordinate the placement of the electrical outlet with the Office of telecommunications design professional.
 - If the building is provided with an emergency generator system or UPS (uninterruptible power supply), the electrical power and lights in the MTC / TC room shall be supplied from that power source.
 - Switches, thermostats or other devices shall be installed beside the door and not in walls containing telecommunications backboards. At no time should these devices be mounted on walls that will contain the TBB or CBB (Communications Backboards).
- d. Room Sizing –
- 1) MTC / TC Room Sizing - The recommended minimum floor dimension for an MTC shall be 90 square feet (i.e. 9' x 10') and the minimum TC on each floor shall be 70 square feet (i.e. 7' x 10'). These minimum sizes shall be increased as building size, floor square footage served or usage increases. The design

professional shall consult with the OTC design professionals if any questions arise concerning the proper sizing. The following recommendations are made for sizing of both MTC and TC:

<u>Area Served</u>	<u>Room Dimensions</u>
5,000 sq ft or less	70 sq ft (i.e. 7' x 10')
5,000 sq ft to 8,000 sq ft	90 sq ft (i.e. 9' x 10')
8,000 sq ft to 10,000 sq ft	110 sq ft (i.e. 10' x 11')

**Single floors that are above 10,000 ft may require an additional communications room due to limits on communications cable lengths.

- 2) Smaller Single Story Buildings – In smaller single story buildings less space is needed. In most cases there will be only one Telecommunications Room, Room or Terminal Can. The following minimum is recommended for these applications:

<u>Building Floor Area Served</u>	<u>Served by</u>
Less than 5,000 sq ft	Shallow Room (3' x 8.5 ') Walk in room (5' x 5')
Less than 1,000 sq ft	Wall Cabinets, Enclosures, etc.

Note: The design professional shall work with OTC design professionals to determine the sizing of any cabinets or enclosures.

- e. Work Clearance - The NEC Section 110-16 provides requirements for working space and clearance around electrical equipment that is exposed (i.e. unguarded, uninsulated).

Provide the following clearances for equipment and cross connect fields in the TR:

- Allow a minimum of 1 meter (3.3 ft) of clear working space from equipment and the wall where wall mounted cross-connect fields are being mounted when determining the size of the Room.
- Allow for 6 inches depth off wall for wall mounted equipment.
- Provide space of at least 4 feet from center line of rack to wall in front and in rear of each equipment rack or cabinet. Provide isles at least 32 inches wide.
- In corners a side clearance of 12inches is recommended.

- f. Relay Racks are typically installed in MTC, TC and CPE rooms for the termination of horizontal data cabling, fiber optics and LAN and other equipment. Installation is typically made by the university OTC. The size of a typical Relay

Rack is 19 inches wide, 7 feet 6 inches high, has a 32" footprint and meets ANSI/EIA-310D.

- g. RFI / EMI Restrictions –
- Due to RFI and EMI the MTC/TC/CPE rooms shall not house any electrical equipment (ie - step down or step up transformers, breaker panels, etc).
 - The equipment room shall be in a location where electromagnetic interference is minimal.
- h. Pathway Installation –
- Conduits are to be clamped to the wall so that they will support the pulling of cable and be bonded to the Telecommunications ground.
 - Conduits shall be dressed even, reamed, cleaned, bushings installed and contain pull cord capable of 200 lbs of pull strength. Sleeves, conduits and raceways must not be left open after installation of cabling. Once cable is installed firestop all sleeves, conduits, and raceways in accordance with building codes.
- i. If two telecommunications rooms are located on the same floor they should be connected with a minimum of 1 - 4 inch conduit. Terminate conduits through the structural floor in the telecommunications rooms three (3) inches above the floor surface. For conduits entering from the ceiling or walls the conduits should be installed to turn down and extend to 8 1/2 feet above finished floor in the Telecommunications rooms or equipment rooms. All conduits shall be dressed at the same level and installed with rigid conduit straps to the wall. Design professionals and installation contractors shall contact the OTC project manager to address exceptions due to structural conflicts.
- j. Cable Tray - Each MTC and TC shall have Cable Tray for the routing of cable inside the rooms that is a minimum of 12" wide installed from corner to corner on every wall mounted 8 feet above finished floor. All tray must be bonded and grounded to the Telecom ground bus bar for the room. Typical cable tray shall be Homaco TRC-512 with all associated hardware. Substitutes must be approved by the OTC.
- When cable trays are approved for use verses conduit for horizontal cabling they should protrude into the telecommunication room and be installed in a continuous loop around the room at the top edge of the 8 foot high TBB which should be on all four walls of the room. Sizing and manufacturer shall be coordinated with OTC.
- k. Ceilings –
- To permit maximum flexibility and accessibility, false ceilings (drop ceilings) are not permitted in MTC or TC rooms.
 - Over-head clearances shall be at least 8 feet (i.e. HVAC duct work, sprinkler heads, etc).

- l. Location –
- To minimize the horizontal cable lengths within a maximum of 295 feet, locate the telecommunications room / room (TC) on each floor as close as possible to the center of the area it is to serve.
 - Ensure that the Telecom rooms are directly accessible from the hallway or other common area. Telecom room should have only one door and not be used as a passage way to other rooms.
 - It is recommended that all TC rooms be vertically aligned (stacked) above the MTC and each other.
- m. Entry –
- Personnel entry to MTC / TC room(s) shall be through a locked door at least 36 inches wide, 80 inches high. The door should open **outward** unless building codes prohibit. Doors swinging in eliminate three feet of usable wall space. In the advent that the door must swing in the design professional shall add the lost wall space in the design and increase room size to compensate. The door is to be keyed by the FSU key bank for the OTC equipment room key. In special applications where a Telecommunications Terminal Cabinet (Box) is used, the box installed shall be capable of being locked. Personal entry to a locked panel shall be via an FSU key bank key for the OTC.
- n. Dust Elimination –
- The walls and ceilings of all equipment rooms shall be dust free and painted with a light color latex paint. The floor shall be tiled with VCT or concrete which has been sealed with sealant.
- o. Room Layout - In new buildings the MTC and TC's shall be designed to be vertically stacked directly over each other. The MTC and TC rooms shall be laid out as to allow for proper use of space.
- All Outside Plant (OSP) 4" conduits entering the MTC shall be located on one wall, preferably starting in the left-hand corner inside the door. If it is not possible to locate in the left-hand corner inside the door, Conduits should be installed beginning in a corner of the room. Avoid installing the OSP conduits or Riser sleeves in the middle of the backboard (wall).
 - It is recommended that the 4" intra-building backbone riser sleeves be placed directly above the OSP conduits in the MTC and in the same location in each stacked TC room so straight pulls can be made from the floor sleeves to the ceiling sleeves.
 - Horizontal conduits shall enter on another wall and other services shall be properly distributed along the remaining walls. Any questions about room layout should be directed to the OTC design professional.
 - Avoid mixing 4" entrance, riser and horizontal conduits.
- p. Grounding / Bonding – Refer to Section V for requirements.

- q. Fire Protection – Provide fire protection for MTC and TC rooms if required by applicable codes.
- r. Environmental Control – Provide heating, ventilation and air conditioning that will maintain continuous and dedicated environmental control 24 hours per day, 365 days per year. Since the MTC and TC rooms house equipment the normal temperature range should be 65 degrees to 78 degrees with 30% to 55% relative humidity. Switches, thermostats or other devices shall be installed beside the door and not in walls containing telecommunications backboards. At no time should these devices be mounted on walls that will contain the CBB (Communications Backboards)

2. Customer Premise Equipment (CPE) Rooms

Some projects may require CPE Room(s) be designed – If CPE rooms are requested in a project by the university they shall include the following:

- a. Wall Linings - At least one wall should be lined with 3/4 inch thick, A/C or B/C Grade Plywood backboard, 8 feet high by 4 feet wide and affixed in such a manner that it will support the weight of the cable, terminals, and other equipment. This allows for coverage of the entire area on which connecting hardware and cable management hardware may be mounted. The plywood should extend from wall to wall. Smooth side shall be out. The plywood backboard shall be void free and treated with two coats of fire retardant paint materials. Use flush hardware and supports to mount plywood. The strength and placement of mounting hardware shall be sufficient to handle the total anticipated load (static and dynamic) and mounting of cabling components. The placement of the plywood backboard shall be on top of the wall covering, i.e. sheet-rock, etc. and is not a substitute for the wall covering.
- b. Lighting –
 - A light intensity level of 70 foot candles minimum should be provided measured at 3.3 ft from the finished floor.
 - Do not use dimmer switches.
 - Locate light fixtures a minimum of 8 ft. 6 in. above the finished floor.
 - Emergency lighting is recommended if available.
- c. Power –
 - Provide at least one dedicated 120VAC, 20 amp (non-switchable) quad receptacle on each wall.
 - Locate receptacles at least 6 inches above finished floor but not higher than 15”.
 - Receptacles must not be controlled by wall switches.
 - If the building is provided with an emergency generator system or UPS (uninterruptible power supply), the electrical power and lights in the CPE room shall be supplied from that power source.

- Switches, thermostats or other devices shall be installed beside the door and not in walls containing telecommunications backboards. At no time should these devices be mounted on walls that will contain the CBB (Communications Backboards)
- d. Room Sizing - The minimum floor dimension for a CPE room contiguous to a MTC or TC room shall be 64 square feet (8'x8'). The minimum floor dimension for a CPE room contiguous to a TC room shall be 24 square feet (6'x 4'). These minimum sizes shall increase as building size and usage increase. The design professional shall consult with the OTC if any questions arise. The NEC Section 110-16 provides requirements for working space and clearance around electrical equipment that is exposed (i.e. unguarded, uninsulated).
- e. RFI / EMI Restrictions –
- Due to RFI and EMI the CPE rooms shall not house any electrical equipment (ie - step down or step up transformers, breaker panels, etc).
 - The equipment room shall be in a location where electromagnetic interference is minimal.
- f. Pathway Installation –
- All conduits and cable trays connecting the MTC or TC rooms to the CPE room shall enter on the same wall that the plywood was attached and extend up or down to the edge of the backboard. The CPE should be connected to the serving MC or TC with a minimum of one 4 inch conduit. Conduits are to be clamped to the wall so that they will support the pulling of cable and be bonded to the Telecommunications ground.
 - Conduits shall be dressed even, reamed, cleaned, bushings installed and contain pull cord capable of 200 lbs of pull strength.
 - Sleeves, conduits and raceways must not be left open after installation of cable. Once cable is installed firestop all sleeves, conduits, and raceways in accordance with building codes.
 - Conduits entering from the floor shall extend 3 inches above finished floor. For conduits entering from the ceiling or walls the conduits should be installed to turn down and extend to 8 1/2 feet above finished floor in the Telecommunications rooms or equipment rooms. All conduits shall be dressed at the same level and installed with rigid conduit straps to the wall. Design professionals and installation contractors shall contact the OTC project manager to address exceptions due to structural conflicts.
- g. Ceilings –
- To permit maximum flexibility and accessibility, false ceilings (drop ceilings) are not recommended in MTC or TC rooms.
 - Over head clearances shall be at least 8 feet (i.e. HVAC duct work).
- h. Location – CPE rooms shall be contiguous to the MTC and TC rooms due to the requirements for horizontal cabling lengths. If this is not possible, these rooms

shall be connected via a series of 4" conduits and the location should be so as to guarantee that the maximum horizontal cable links lengths do not exceed 295 feet from the horizontal termination in the CPE to the Workstation outlet.

- i. Entry - Personnel entry to MTC / TC room(s) shall be through a locked door at least 36 inches wide, 80 inches high. The door should open **outward** unless building codes prohibit. Doors swinging in eliminate three feet of usable wall space. In the advent that the door must swing in the design professional shall add the lost wall space in the design and increase room size to compensate. The door is to be keyed by the FSU key bank for the OTC equipment room key. In special applications where a Telecommunications Terminal Cabinet (Box) is used, the box installed shall be capable of being locked. Personal entry to a locked panel shall be via an FSU key bank key for the OTC.
- j. Dust Elimination - The walls and ceilings of all equipment rooms shall be dust free and painted with a light color latex paint. The floor shall be tiled with VCT or concrete which has been sealed with sealant.
- k. Room Layout -
 - Conduits entering the CPE room shall extend to the Plywood backboard or approximately 8 1/2 feet AFF. Cable Trays located within the ceiling space of the room should never be below 8 feet from the finished floor. Conduits and cable tray shall be rigidly installed to the walls.
 - For specific CPE room layout the design professional shall consult with the OTC design professional.
- l. Work Clearance - The NEC Section 110-16 provides requirements for working space and clearance around electrical equipment that is exposed (i.e. unguarded, uninsulated).

Provide the following clearances for equipment and cross connect fields in the Equipment room:

- Allow a minimum of 1 meter (3.3 ft) of clear working space from equipment and the wall where wall mounted cross-connect fields are being mounted when determining the size of the Room.
- Allow for 6 inches depth off wall for wall mounted equipment.
- Provide space of at least 4 feet from center line of rack to wall in front and in rear of each equipment rack or cabinet. Provide isles at least 32 inches wide.
- In corners a side clearance of 12 inches is recommended.

Relay Racks are typically installed in MTC, TC and CPE rooms for the termination of horizontal data cabling, fiber optics and LAN and other equipment. Installation is typically made by the university OTC. The size of a typical Relay Rack is 19 inches wide, 7 feet 6 inches high, have a 32" footprint and meet ANSI/EIA-310D.

- m. Grounding / Bonding – Refer to Section V for requirements.
- n. Fire Protection – Provide fire protection for CPE rooms if required by applicable codes.
- o. Environmental Control – Provide heating, ventilation and air conditioning that will maintain continuous and dedicated environmental control 24 hours per day, 365 days per year. Since this room houses equipment it is recommended that at a minimum temperature range should be 65 degrees to 78 degrees with 30% to 55% relative humidity. For specific application the design professional shall consult with the department to obtain current heat load data and future heat load data. Switches, thermostats or other devices shall be installed beside the door and not in walls containing telecommunications backboards. At no time should these devices be mounted on walls that will contain the CBB (Communications Backboards)

3. Cabinets and Terminal Boxes –

For existing installations, retrofits and smaller one story buildings, it is recognized that a dedicated room may not be an option. If a dedicated MTC or TC room can not be constructed, then the requirements for a locked terminal box on an exposed wall space terminal location shall be used. The terminal boxes shall include:

- a. A linear, contiguous wall space as follows:

<u>Building Usable Floor Area</u>	<u>TC Wall Length</u>	<u>MTC Wall Length</u>
Up to		
10,000 Square Feet	30 inches	60 inches
20,000 Square Feet	36 inches	72 inches
30,000 Square Feet	45 inches	90 inches
40,000 Square Feet	60 inches	120 inches
50,000 Square Feet	90 inches	180 inches
60,000 Square Feet	90 inches	180 inches
70,000 Square Feet	120 inches	240 inches

- b. Terminal Boxes shall be a minimum of 8.00 inches deep and shall contain within them a mounted ¾” A/C or B/C grade plywood for mounting of hardware. The plywood shall cover the back of the cabinet, smooth side out.
- c. Wall Lining - The wall area for the terminal box should be covered with ¾ inch thick, A/C or BC Grade Plywood backboard, 8 foot high by 4 foot wide and affixed in such a manner that it will support the weight of the terminal box, cable, terminals, and other equipment. This allows for coverage of the entire area on which connecting hardware and cable management hardware may be mounted.

Smooth side shall be installed out. The plywood backboard shall be void free and treated with two coats of fire retardant materials. Use flush hardware and supports to mount plywood. The strength and placement of mounting hardware shall be sufficient to handle the total anticipated load (static and dynamic) and mounting of cabling components.

- d. Working Space –
A clear working space extending 48 inches from wall is required.
- e. Lighting –
A light intensity level of 70 foot candles minimum should be provided in front of the terminal box.
- f. Power –
 - Provide at least one dedicated 120 VAC, 20 amp (non-switchable) quad receptacle on the wall. Locate the receptacle at least 16 inches above finished floor below the terminal box.
 - Receptacles must not be controlled by wall switches.
 - If the building is provided with an emergency generator system or UPS (uninterruptible power supply), the electrical power and light in front of the terminal box shall be supplied from that emergency power source.
- g. Grounding / Bonding – See Section V. for Grounding and Bonding design.
- h. Location - A location adjacent to service entrance conduits and conduits to the equipment room.
- i. RFI and EMI Interference - Due to RFI and EMI, locked panel boxes shall not be located within 15 feet of any electrical equipment (i.e. - transformers, breaker panels).
- j. All conduits and cable trays shall terminate on the same wall and directly above the plywood to which the locked panel box is attached. Configuration of conduits and cable tray shall follow the same design configuration requirements as the MTC and TC rooms.
- k. Overhead clearance – Over-head clearances shall be at least 8 feet, 6 inches. Piping, HVAC duct work, sprinkler heads, etc shall be placed to assure a minimum clearance of 8 feet.

III. MEDIA

A. OUTSIDE PLANT CABLING

The Florida State University has an underground duct system of 4” conduits and manholes used for the installation of OSP cables between buildings. Use of the conduit and manhole system shall be pre-approved by the OTC.

1. Approved Outside Plant (OSP) Cable

- a. Approved Copper Cables - Cable used for outside plant applications (between campus buildings) shall be rated for underground duct and direct buried applications or aerial and duct applications and shall meet REA (PE rated) or Bell specifications. Either filled OSP rated cable or air core pressurized OSP rated cable shall be used. Underground cable placed in the university manhole duct system is the OSP installation of choice.

The use of Direct Buried or Aerial Cable must have prior approval of the Office of Telecommunications.

- b. Approved Fiber Optic Cables – Fiber Optic cable used in OSP applications shall be Loose buffer tube and jell filled. The standard fiber cable configuration for university backbone fiber cable is a Corning Loose buffered Hybrid 96 fiber optic cable with 84 single mode and 12 50/126 micron multimode fibers. The standard entrance Fiber optic cable is a 18 hybrid fiber optic cable with 12 - Single Mode fibers and 6 - 50 /125 OFLM SX+ multimode fibers. Installed fiber shall meet all requirements of the ANSI/TIA/EIA 568A and 568B, Commercial Building Telecommunications Standard. Refer to section X for standard materials.

2. OSP Cable Installation Guidelines –

- a. Underground Cable – Underground cable is Outside Plant (OSP) cable that is placed in the University manholes / ductbanks. The following shall apply when installing cable in the University Manholes / ductbanks:
- Installation of new underground cable shall use the bottom-most accessible conduit in the ductbank. Installation shall require coordination with the OTC. A pull cord shall be installed with cable and left in place for future use. Conduit shall be filled to 60% before next vacant duct is used.
 - Manhole Safety - The installer must follow proper safety procedures for all federal, state, local, and university environmental, health and safety regulations concerning confined space entry, and shall meet requirements as set forth by the Occupational Safety and Health Administration (OSHA) for permit-required confined spaces and telecommunications. **All safety equipment required for work in confined space must be used and must be provided by the installer.** A barricade with audio and visual warning devices and an observer at the opening must be used at each manhole while it is open and entered by installation personnel.
 - OSP Cables are not non-fire rated and shall not run more than 50 feet within the building between the entrance point and the termination unless

a rigid metallic conduit is used to enclose the cable. The conduit must be grounded.

- b. Direct Buried Cable – is cable that is buried by the use of trenching, plowing or boring in the ground. Direct Buried cable is not preferred or recommended. In cases where direct buried is approved by the OTC, the following shall apply:
 - The installer shall notify OTC Engineering prior to any work beginning.
 - The installer shall coordinate the location of all utilities prior to placement of cable.
 - The cable shall be placed at a minimum depth of 24” from the top of the cable to the surface.
 - Documentation – As built drawings shall be provided to the OTC.
 - The installation of direct buried cable shall adhere to all state, local and federal codes and laws including the Occupational Safety and Health Administration (OSHA).
 - To minimize any chance of accidental dig-up, place a plastic warning tape a minimum of 18 inches below the surface and directly above the cable. Tape will be provided by the Office of Telecommunications on request.

3. OSP Cable Lightning Protection – All OSP cables shall be protected at the point of entrance into the buildings (in the MC’s) on both ends. Lightning Protection shall meet the safety code requirements as set forth in ANSI/NFPA 780 (Lightning Protection Code), NEC, ANSI/TIA/EIA-607, UL497, UL96, ANSI/IEEE Std. 1100-1992 and Bellcore Standards. See OTC recognized hardware, media and termination materials section for suggested materials.

Gas Tube Protectors and Solid State Protectors are the protectors of choice for the OTC.

B. INTRABUILDING BACKBONE (VERTICAL) DISTRIBUTION CABLING

The Intra-building Backbone Distribution Cabling System provides telecommunications cabling from the Main Telecommunications Room (MTC) which houses the telecommunications Main Distribution Frame (MDF) to the Telecommunications rooms (TC) containing Intermediate Distribution Frames (IDF) on each floor and to the Customer Premise Equipment Room (CPE). Intra-building Backbone cabling will include all cables, intermediate and main cross-connects, mechanical terminations and patch cords and/or jumpers used for backbone to backbone cross-connection.

Topology – The Backbone system uses a Physical Star Topology with a minimum of one each, voice and data riser cable from the Main Telecommunications Room (MTC) to each Telecommunications Room (TC). Dedicated counts shall be provided with no multiple counts of the same cable terminated in any other TC (No Bridged Taps). All cables are to be homerun. Voice and data cables will be separated on the termination backboard.

An Intra-building star wiring topology shall:

- Have no more than two (2) levels of cross-connections.
 - Connections between any two telecommunications rooms should pass through no more than three cross-connects. (not including the cross-connects between the backbone and the horizontal cabling serving the outlet.
 - Shall pass through no more than one backbone cross-connect to reach the highest level cross-connect. (MDF in MTC)
1. Cable sizing - (1) Intra-building Backbone Voice cables are specifically used for carrying voice grade services and will be sized to provide enough pairs to provide no more than a 60% fill when configured to serve each jack in the horizontal system being served from the TC. Other factors considered when sizing the riser cable include flexibility with respect to services provided, required useful life of the wiring, estimated growth and present size of user population. (2) Backbone Data cables are used primarily for special applications such as 4 wire data circuits and other special circuits, T-1 circuits, ISDN lines, etc and will be sized to provide a minimum of 25 pairs.
 2. Cable Types – Intra-building Backbone (Vertical Riser) Cable shall consist of:
 - a. Voice Backbone - The Voice Backbone Riser Cable shall be a category 3 or higher, 100 ohm, +/- 15% over 1 Mhz, Unshielded Twisted Pair (UTP) Multi-pair, 24 AWG, solid copper cable, with twisted thermoplastic insulated conductors formed into 25 pair binder groups. See OTC recognized hardware, media and termination materials section for suggested materials.

The cable shall meet the requirements applicable to Multi-pair riser cable as defined in the following:

- ANSI/TIA/EIA 568A and B - Commercial Building Telecommunications Wiring Standards
 - ICEA Publications S-80-576, Cable Specifications.
 - ASTM D-4566 (Performance measurements).
- b. CATV Coaxial Intra-building Backbone -

The Intra-building Backbone for the University CATV system consist of a single .500 Riser Rated, jacketed, 1000 MHZ coaxial cable starting in the Telecommunications MTC and running through each TC with the end termination being in the TC on the uppermost floor. The topology of the riser shall be a Loop-Thru (Series) Design. Connection at each floor will be made via taps and other passive devices. The OTC will work with the design professional to determine exact transmission design, media, equipment, hardware needs and termination methods. There shall be a lockable Terminal box in each TC for termination of

CATV equipment and passive devices. See OTC recognized hardware, media and termination materials section for suggested materials.

The CATV terminal box sizes shall be a minimum of:

- For Amplifiers – 24”H x 18”W x 8”D
- For Passive Taps only – 18”H x 12”W x 8”D

CATV terminal boxes shall have the back lined with ¾” A/C or B/C grade Plywood.

- c. Optional Intra-building Backbone Vertical Riser Cabling - Additional vertical cabling may be required to satisfy user specific applications. Such cabling shares the telecommunications equipment rooms. Optional cables are determined by the department requiring the service and will not replace basic building wiring requirements. The following are examples of optional vertical media:
- 1) Optic Fiber Backbone Riser– Optic Fiber Riser used for data networking and other high speed applications shall be Multi-mode, grade-index (50/125um) optic fiber cable. This backbone fiber optic cabling will be installed and terminated between the MTC and each TC. The minimum standard Optic Fiber is a Corning riser or plenum rated tight buffer, 6 fiber cable. The OTC will work with design professionals and University networking groups to design the riser based on specific fiber needs. Optical transmission performance will be a minimum of 3.50/1.5 db/km and 500/500 MHz-km @ 850/1300nm. See OTC recognized hardware, media and termination materials section for suggested materials.
 - 2) Special Data Applications may require Copper Backbone Data Riser to connect Data network equipment on different floors. For data backbone riser each circuit shall be supported by a separate four pair, 100 ohm, UTP, 24 AWG, Category 5 Enhanced Cable with stable electrical performance at up to 350 MHz. The cable shall be white in color. All Data Riser Four Pair Cables shall be bundled together and installed in the same sleeve or conduit. This cable shall meet all of the requirements of ANSI/TIA/EIA -568A and 568B Commercial Building Telecommunications Wiring Standard, ICE Pub S-80-576, ISO/IEC 11801 and ASTM D-4566 (Performance measurements).
 - 3) Single-mode (8.3/125nm) optic fiber cable will be installed and terminated on each floor as design requires. The OTC will work with the design professional to determine exact fiber count and termination methods. Cable will be Corning Tight Buffer riser and plenum rated standard duty Fan-Out cables. Optical transmission performance will be a minimum of 1.5/1.25 db/km @ 1300/1550 nm.

3. Code Considerations for Intra-building Backbone Plenum and Riser Rated Cable–

The National Electrical Code (NEC), Chapters 7 and 8 impose specific requirements for building backbone systems. These requirements are designed to prevent the spread of flame and smoke from floor to floor and are related to the telecommunications rooms, the media and support facilities. Applicable Plenum rated or Riser rated cable shall be used when required.

4. Labeling - All vertical riser cables shall be marked with the cable usage (i.e. Voice or Data), cable number, size, date of installation, and location of the termination of the other end of the cable. Both ends of the cable should be marked. Information will be physically marked by attaching a permanent cable tag on both ends.

5. Intra-building Backbone Cross-Connection

- a. Voice circuit cross connection – Cross connection between terminals for Voice Circuits will use one pair, twisted, 24 AWG jumper wire. The color of this wire will be White/Blue. No more than one wire shall be punched down (terminated) on a single terminal. A red plastic F clip terminal insulator will be placed over terminals used for Digital instruments, special circuits, T-1's etc., terminated on voice cabling. Jumpers shall utilize wire management (“D” Rings) and shall not be run diagonally. A 2” minimum drip loop shall be provided at each jumper end when terminated. Jumpers in the horizontal cross-connect shall be minimized and shall not exceed 6 meters (20’). The horizontal cross connect jumper length shall be included in the maximum combined jumper length in the telecommunications room of 7meters (23’). Cross connection of Intra-building backbone riser cabling shall meet all recommendations of ANSI/TIA/EIA 568A and 568B.
- b. Fiber Optic Jumpers – All fiber optic cross-connect jumpers shall be single fiber Corning fiber jumpers or dual fiber jumpers. Fiber jumpers shall meet FDDI, ANSI/TIA/EIA 568A and 568B standards. All jumpers shall be pre-connectorized. Multimode fiber jumpers shall be 50/125µm, OM3 with SC connectors as specified for the specific project and shall be sized in length for the application. Single Mode 8.3/125µm should be OM3 with SC connectors or LC connectors and sized in length for the application.
- c. Data Circuits Cross-Connects – Four Pair, UTP Data Riser cables are terminated on RJ45 Category Enhanced jacks in data patch panels in a Relay Rack. A Category 5 Enhanced pre-connectorized, RJ45 patch cable shall be used to cross - connect the Patch panel jack to the LAN equipment. The data patch cables on both ends shall be limited to a total of 7 Meters (33’) to keep the total length of cable and patch cords within the 100 Meter (328’) length limit. Cable Management devices shall be used for routing of patch cables. Cross connection of the Intra-building backbone riser cable shall meet all recommendations of ANSI/TIA/EIA-568A and B. Data patch cords are part of a structured cabling

system that has been warranted by the manufacturers to meet guaranteed performance while working with the selected UTP cable and termination hardware. Patch cords are normally the responsibility of the individual departments. Patch Cords found in the “OTC RECOGNIZED HARDWARE, MEDIA AND TERMINATION MATERIALS” section are recommended for optimum performance of the horizontal channel.

7. Intra-building Backbone Cabling Lengths

The Main Telecommunications Room (MTC) and Floor serving Telecommunications Rooms (TC) locations should take into consideration cable length requirements. To minimize cable distances, MTC’s and TC’s should be located near the center of a floor or the area it is planned to serve. Distance limitations are provided to ensure that the backbone can accommodate voice and data transmission applications. The total length of transmission cable between the Main Telecommunications Room (MTC) and either a Telecommunications Room (TC) or Customer Premise Equipment Room (CPE), including any intermediate cross-connects depends on the type cable used.

Intra-building backbone riser cabling lengths are as follows:

	Main (MDF) Cross-Connect	Intermediate Cross-Connect	Horizontal Cross-Connect
	<u>MDF to IC</u>	<u>IC to HC</u>	<u>Total Length</u>
100 Ohm UTP (voice)	300M (984’)	500M (1,640’)	800M (2,624’)
100 Ohm UTP (data)			90M (295’) *
50.5/125 MM Optic Fiber	1,500M (4,920’)	500M (1,640’)	2,000M (6,560’)
62.5/125 MM Optic Fiber	1,500M (4,920’)		500M (1,640’)
2,000M (6,560’)			
Single Mode Optic Fiber	2,500M (8,200’)	500M (1,640’)	3,000M (9,840’)
150 Ohm STP-A			90M (295’) *

*Notes: Total length between active equipment connections should not be greater than 100 Meters (328’), including patch cables on both ends.

- a. Cross-Connect to Equipment Length – When telecommunications equipment is connected directly to the main or intermediate cross-connects, the connecting cables must be no more than 30M (98’).
- b. Fiber Maintenance Loop – There shall be a 20 feet maintenance loop on each end of any installed intra-building fiber as well as a minimum of one full loop around the interior of each manhole. These maintenance loops must be included in the total limit.

8. Intra-building Backbone Cable Bend Radius –

Cables shall not exceed the following bend radius –

- Copper Cables less than 2” in diameter – 6 X outside diameter.
- Copper Cables greater than 2 “in diameter – 10X outside diameter.

C. HORIZONTAL DISTRIBUTION CABLING

The horizontal cabling is installed in a star topology with a dedicated cable to each jack. It extends from the work area telecommunications outlet to the telecommunications room.

Horizontal Cabling Systems shall meet requirements as specified in ANSI/TIA/EIA 568

A. The horizontal cabling typically runs horizontally along the floor or ceiling of a single floor.

1. Minimum Station Outlet Wiring - Cabling shall be provided to support a minimum of two station jacks at each workstation location, one voice and one data jack. The horizontal cable extends from the station outlet (jack) to the horizontal termination block or patch panel in the Telecommunications Room (TC) or Main Telecommunications room (MTC).
 - a. Voice – Each voice jack shall be supported by a four pair, 24 AWG, 100 ohm, Category 3 or higher, UTP cable. This cable will meet or exceed standards and requirements as set forth in ANSI/TIA/EIA 568A and 568B, Commercial Building Telecommunications Wiring Standard Plenum rated cable must be used where required.
 - b. Data – Each data jack shall be supported by a four pair, 24 AWG, 100 ohm, UTP cable for use with data at up to 100 Mbps with stable electrical performance at up to 350 MHz as tested with a passive tester. The horizontal data cable shall be Category 5 Enhanced cable and as a minimum shall meet all of the requirements of ANSI/TIA/EIA 568A and 568B and ISO/IEC 11801 for Category 5 Enhanced cable. The Category 5 Enhanced data cable forms one part of a matched impedance structured horizontal cabling channel. The horizontal cable is part of a structured cabling system that has been warranted by the manufacturers to meet guaranteed performance while working with the selected horizontal termination hardware and patch cords. Horizontal Cable recognized for use at FSU may be found in the “OTC RECOGNIZED HARDWARE, MEDIA AND TERMINATION MATERIALS” section. The selected cable has been recognized as a standard and was selected for optimum performance of the horizontal channel. Plenum rated cable must be used where required. All four pairs must be terminated on both ends.
2. Optional Station Outlet Wiring – The use of optional cables will be determined by the department requiring the service and will not replace the basic building wiring requirement. The following are examples of optional media. Communications media

due to industry and technical advances are constantly changing. Special consideration should be used when using other media.

- a. CATV outlets require the use of RG6, 1,000MHZ, 90% shield, coaxial cable. This cable can be installed in homerun conduit or cable tray/open ceiling. However, plenum rated cable must be used where required.
 - b. Fiber optic - Multi-mode - (50/125um) optic fiber cable will be installed and terminated to each work station as design requires. The OTC will work with the design professional to determine exact fiber counts and termination methods. Cable will be Corning standard duty, tight buffered cable. Optical transmission performance will be a minimum of 3.5/1.5 db/km and 500/500 MHz-km @ 850/1300nm. This cable can be installed in homerun conduit or cable tray/open ceiling. However, plenum rated cable must be used where required.
 - c. Fiber Optic - Single-mode - (8.3/125nm) optic fiber cable will be installed and terminated to each work station as design requires. The OTC will work with the design professional to determine exact fiber count and termination methods. Cable will be Corning standard duty, tight buffered cable. Optical transmission performance will be a minimum of 1.5/1.25 db/km @ 1300/1550 nm. This cable can be installed in homerun conduit or cable tray/open ceiling. However, plenum rated cable must be used where required.
3. Wall mounted instrument wiring - Wall phones, pay phones and other installations requiring the use of a wall mount jack shall be supported by a four pair, Category 3 or higher, 24 AWG, 100 ohm, UTP cable. This cable will meet or exceed standards and requirements that are applicable to four pair inside wiring cable for plenum or general wiring within a building as defined in ANSI/TIA/EIA 568A and 568B, Commercial Building Telecommunications Wiring Standard. Plenum rated cable must be used where required.
4. Horizontal Cabling System Design Considerations
- a. Horizontal Cable LINK and CHANNEL Lengths–
 - 1) Horizontal Cabling LINK – The LINK encompasses all components of the horizontal cabling subsystem and includes the following:
 - Telecommunications Outlet
 - Cable between the Outlet and the Horizontal Cross-connect
 - Transition or consolidation points
 - Patch panel or connecting block in the horizontal cross-connect.
 - Jumpers or patch cords that join the patch panels or connecting blocks within the horizontal cross-connects.

The horizontal cabling LINK lengths are as follows:

- Horizontal Cable between the Horizontal cross-connect and the outlet - 90 meters (295 ft) independent of media type. This is the cable length from the mechanical termination of the media in the telecommunications room to the telecommunications outlet work area.
- Jumpers or patch cords in the horizontal cross-connect – <6 meters (20 ft)
- **Maximum Total LINK Length – 96 meters (325 ft)**

Horizontal Cabling Link

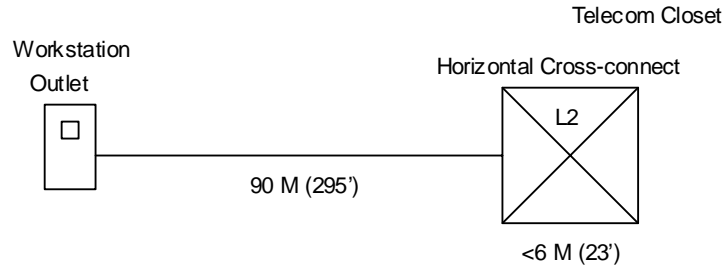

- Basic LINK – The Basic LINK is the cable installed from the Outlet to the Horizontal cross-connect and includes the Horizontal cable, the outlet and the connecting hardware of the horizontal cross-connect.
 - **Maximum Total Basic LINK length – 90 meters (295 ft)**
- Horizontal Cabling CHANNEL – The CHANNEL encompasses all components of the horizontal cabling LINK, plus the equipment cords at the work station and in the room. The horizontal channel contains all of the components required to support telecommunications applications over horizontal cabling.

Horizontal Cabling CHANNEL lengths –

- The Horizontal CHANNEL length includes the total length of the LINK and the equipment patch cords or cables.
- Combined length for the patch cords and cables used to connect the work area and telecommunications room equipment to the LINK - < 10 meters (33 ft) with an allowance of <7 meters (23 ft) of combined length per channel for patch cords, jumpers and equipment cables in the Telecommunications Room and 3 meters (10 ft) for equipment patch cords at the work station.
- Maximum Total Channel Length - 100 meters (328 ft).

Horizontal Cabling Channel

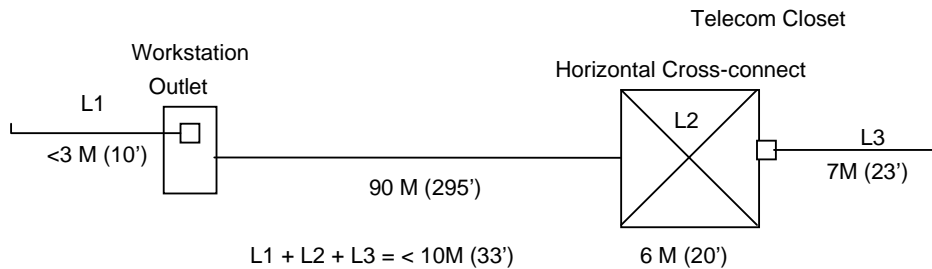

a. Cabling Practices –

Performance of installed cabling systems may be degraded by cabling practices relating to cable terminations, cable management, cross-connects and connections in close proximity. Cabling Practices shall meet installation requirements of ANSI/TIA/EIA 568A and 568B. It is recommended that the following precautions be taken during cable system installation.

- 1) Maximum Pulling Tension – the maximum pull force for a four pair horizontal UTP cable is 110N (25 lbs).
- 2) The following cable management precautions should be followed:
 - Eliminate Cable Stress caused by:
 - Limit spans to 1.5 M (5 ft) or less in suspended cable runs.
 - Do not cinch cable bundles tightly. Velcro straps should be used on all data cable bundles and not cable ties to avoid over-tightening and deformation of the cable jacket. Avoid deforming the jacket.
 - Do not twist the cable during installation.
 - Reduce untwisting of copper pairs by stripping back only as much jacket as is required to perform connecting hardware terminations.
 - Ensure all horizontal cable meet bend radii.
UTP and STP – 4 X outside diameter.
 - Cable termination preparation – Remove only as much jacket as is needed for termination and trimming. Minimize the amount of untwisting of pairs when terminating the cable to devices. Untwisting of Category 3 and 4 cables shall not exceed 1 inch. Untwisting of Category 5 and enhanced Category 5 cable shall not exceed ½ inch.

b. Cable Slack – When cable runs are being installed, provide additional slack at both ends to accommodate future cabling system changes. The recommended minimum amount of slack is:

- 1) At the Telecommunications Outlet install the following slack –

- Twisted pair Cables – 30 cm (12 inches)
 - Fiber Optic Cables – 1 meter (3.3 ft)
- 2) In the MTC, TC and CPE rooms - install 3 M (10 ft) of slack for all UTP, Fiber and CATV Coax cable. The slack loop is to be placed in the overhead relay rack. Specific cable radii shall apply.

Include the slack in all length calculations to ensure that the horizontal cable does not exceed 90 M (295ft).

IV. TERMINATION

Termination of telecommunications cabling and termination devices used shall meet all requirements as specified by FCC part 68, ANSI/TIA/EIA 568-A, IEC 603-7, ISO/IEC 8802-5, ANSI/TIA/EIA-604-3 and other applicable codes and standards.

A. WALL AND RELAY RACK LAYOUT CONSIDERATIONS

A properly designed and configured termination layout is essential to the management of telecommunications infrastructure. The Main Telecommunications Room (MTC) and Telecommunications Rooms (TC) shall follow the guidelines as set forth in this document. Special applications and/or configurations for terminations shall be pre-approved by the OTC.

1. Wall Layout Considerations – The layout and use of backboard space shall follow the following recommendations:
 - a. Grouping - All termination devices for each type of cabling (i.e. Backbone voice, horizontal voice, backbone riser data, etc) should be grouped in separate termination fields and not mixed. Space shall be left in the field for the addition of termination devices in the future.
 - b. Top Clearance - A clear space of 5 – 6 inches shall exist above the top Termination Device and the top edge of the Backboard to allow for the installation of cable management hardware and the routing of cable.
 - c. Bottom Clearance - A clear space of 5 – 6 inches shall exist from the bottom of the bottom Termination Device and the bottom edge of the Backboard to allow for the installation of cable management hardware and the routing of cable.
 - d. Corner Clearance - There shall be a clear space of 12 inches from the Corner of any backboard to a termination device.

- e. Arrangement Considerations - Cross-connect fields and active equipment installed on the backboards must be placed to allow cross-connections and interconnections via jumpers and patch cords whose lengths per channel do not exceed:
- 6 meters (20ft) for patch cords or jumpers in the horizontal cross-connect.
 - 7 meters (23 ft) total for patch cords, jumpers and equipment cables connected to the horizontal cross-connect.
 - 20 meters (66 ft) for patch cords or jumpers that serve Main or intermediate cross-connects in the TC.
- f. Cable Routing – Cables will be routed around the perimeter of the backboard and fed vertically from the bottom of the backboard or from the top but should not be installed from both directions. All cables must be routed from either the top or bottom. No horizontal or diagonal routing of the cable to the terminal devices (blocks) is permitted. Cables must be run in lines perpendicular and parallel to the edges of the backboard. Cables must be secured with clamps or placed in "D" rings routed around the perimeter of the backboard or through cable trays above the backboard. In TC rooms, all Riser Cables shall be installed in one section of the backboard to extend up the backboard from the floor conduit or sleeve to the conduit or sleeve to the next floor. This Riser section of the backboard shall be dedicated and kept clear of any termination devices. Cable management devices (“D” Rings) shall be used for the routing of all cables on the backboards. Cables shall be routed through "D" rings to the terminal blocks. "D" rings shall be metal with round, smooth edges and sized for the estimated fill. The "D" rings shall be large enough to provide no more than a 60% fill. "D" rings will be provided both horizontally and vertically on the backboard.
- g. Leveling – All termination devices (blocks) shall be installed in vertical rows and each device shall be arranged using a level.
- h. Distance between termination devices (Blocks) – There shall be a minimum of 2 inches of horizontal distance between each row of termination devices (blocks) to allow for routing of jumpers. A minimum of two “D” ring or other wire management device shall be installed in the open space between the rows even with the top edge of the top termination device (block) in a row and even with the bottom edge of the bottom termination device (block). Additional wire management device may be used for long rows with no more than one wire management device every second termination device (block).
- i. Cross-Connect Fields Color Coding – The following color codes for cross-connect fields shall apply:
- | | |
|----------|--|
| Orange - | Demarcation Point (CO) |
| Green - | Public Network Connection in Building being served |
| Purple - | Common Equipment, PBX, LAN's, MUX, etc. |

White -	First Level Backbone. Main cross-connect to Intermediate cross-connect or horizontal cross-connect.
Gray -	Second Level Backbone. Intermediate cross-connect to a horizontal cross-connect.
Blue -	Horizontal Cable.
Brown -	Inter-building backbone. (campus building to building). Note: Brown takes precedence over white or gray for inter-building runs.
Yellow -	Miscellaneous (alarms, security systems, etc)
Red -	Reserved for future use.

- j. Termination cabinets – when the telecommunications room (MTC or TC) is to be a shared facility all voice termination devices (blocks) and CATV cabling termination shall be installed in separate lockable terminal cabinets mounted on the wall backboard. These cabinets shall be sized by the design professional and shall be a minimum of 24”W x 36”H x 5.5 “D. The cabinets shall be backed inside with ¾” A/C or B/C grade plywood and sized for no more than 60% fill at the time of installation to allow for future growth.
2. Relay Rack Layout Considerations – Relay Racks are typically installed in MTC, TC and CPE rooms for the termination of horizontal data cabling, fiber optics and LAN and other equipment. Fiber Panels will be installed at the uppermost slot on the relay rack. The positioning of data patch panels, fiber panels, LAN and other equipment shall be determined with input from the individual departments sharing the Relay Rack. The size of a typical Relay Rack is 19 inches wide and 7 feet 6 inches high. Relay Racks shall meet ANSI/EIA-310D. Typical Data Patch Panels are 24 port or 48 port and include horizontal wire management at the base of each patch panel. In addition, vertical wire management devices shall be installed on both sides of the relay rack but not interfere with the addition of additional relay racks.

The placement and clearances required for the placement of Relay Racks are as follows:

- The NEC Section 110-16 provides requirements for working space and clearance around electrical equipment that is exposed (i.e. unguarded, un-insulated). Per NEC allow a minimum of 1 meter (3.3 ft) of clear working space from equipment and wall mounted cross-connect fields.
- The typical footprint for the placement of a relay rack is 32” deep and 19” wide. A 32” space for an isle should be left in front and in the rear of the relay rack.
- Equipment and connecting hardware may extend beyond the relay rack by up to 24”. Clearance should be measured from the outermost surface of these devices rather than the mounting service of the rack to allow proper clearance for working personnel.

B. OUTSIDE PLANT TERMINATION

1. Termination Devices

- a. OSP Voice Termination – Sprint is the voice services provider for the University and provides copper cabling for voice services to the Building Main Telecommunications Room. Sprint provides all termination devices and lightning protection equipment. Spring installations are coordinated by the Office of Telecommunications. Sprint cables will be terminated in terminals on 66 blocks and a tie cable will be provided from the Sprint terminals to the building riser enclosure for cross connects.
- b. OSP Fiber Optic Termination – Backbone and Entrance Hybrid fiber optic cables will be terminated in the main telecommunications room of the building and in the fiber hub building. Fiber cables will be terminated in a Corning Pretium 12 slot cabinets on both ends. Multimode and single-mode fibers will be terminated using pre-wired, pigtailed 12 port CCH panels with LC connectors. Single mode fiber LC connectors will be APC. All connections will be fusion spliced.
- c. OSP CATV Termination – CATV termination will be accomplished based on the OTC design professional recommendations.

C. INTRA-BUILDING BACKBONE (RISER) TERMINATIONS

1. Termination Devices – Intra-building Backbone (Vertical Riser) cabling connects the Main Cross-Connect (MDF) to IDF's in the individual telecommunication rooms (TC's) for cross-connection to the horizontal cabling via the horizontal cross-connect.
 - a. Voice Riser Termination – voice riser cables will be terminated on Siemon S66M1-50, 50 pair termination blocks. These terminal blocks shall be mounted on the plywood backboard and must be mounted with Siemon S89B brackets. Equivalent termination devices and brackets must be capable of terminating a minimum of 50 pairs on a block no larger than 4" x 12" and approved by OTC.
 - b. Data Riser Termination (copper) Data Riser cables are terminated on RJ45 Category 5 Enhanced jacks on data patch panels in a Relay Rack. The data jack shall be an 8 position, RJ45 jack rated for category 5 E (Enhanced) and shall be terminated following T568-A pin / pair assignments.

The category 5E data jack shall perform with stable electrical performance at up to 350 MHz and at a minimum shall meet all of the requirements of ANSI/TIA/EIA 568A and 568B and ISO/IEC 11801 for category 5 cables.

- c. Fiber Optic Riser Cable Termination – Fiber Optic cables for data networks and other applications will be routed to the equipment relay racks. Fibers will be terminated with SC 50 micron (multimode) and SC (single mode) connector in lockable WIC/PIC cabinets that are manufactured by Corning. Cabinets for fiber will be installed in the top most slots of the relay rack. Sizing of these Cabinets will be done on a case by case basis by the OTC design professional.
- d. CATV Riser Termination – All CATV terminations will be placed in a lockable box located in each room, on the backboard. The .500 riser cable shall be terminated with a standard .500 connector for connection to passive and active equipment in the termination cabinet. A box with a minimum size of 24”H x 18”W x 8”D shall be provided. Exact sizing shall be coordinated with the OTC design professional.
- e. Termination of Optional Media – Selection of termination equipment and termination techniques shall follow guidelines as specified by individual manufacturers and applicable standards and codes. Termination layout shall be coordinated with the OTC design professional. Termination of optional equipment will require appropriate termination.

D. HORIZONTAL TERMINATIONS

1. Station Outlet Terminations

- a. Outlet Location - Workstation outlets shall be located on the wall 18" above finished floor level.
- b. Outlet Selection and Configuration -
 - 1) Outlet Faceplate Selection - A standard flush, wall mounted telecommunications single gang outlet faceplate with cutouts for jack inserts is the outlet style of choice. A quad faceplate is optional for locations requiring services that can't be serviced out of a single gang faceplate. Outlets may be mounted in a surface mounted box with associated wire mold, if wall construction precludes internal wiring.
 - 1a). Residential Halls - An angled flush, wall mounted telecommunications single gang outlet faceplate with cutouts for jack inserts is the outlet style of choice. A quad faceplate is optional for locations requiring services that can't be serviced out of a single gang faceplate. Outlets may be mounted in a surface mounted box with associated wire mold, if wall construction precludes internal wiring.

- 2) Outlet Configuration - The outlet shall have a minimum of 4 ports for snap in modular jack inserts. A minimum of two (2) telecommunications modular jacks shall be provided in each outlet, one voice and one data jack. Both jacks will be located on a single outlet faceplate assembly. Voice jack inserts shall be arranged in the top row and data jack inserts in the second row. All unused ports shall be filled with blank inserts. Outlets shall have icon labels to identify voice, data, CATV and other inserts. Growth in spare slots will take place from top to bottom. Special connectors such as "F" connectors will be mounted in the bottom jack position if this option is requested.
- c. Standard Jack Insert Configuration and Termination-
- 1) Voice Jack Insert termination – The voice jack insert shall be a 6 position, RJ11, USOC insert rated for Category 3. The 4 pair, 100 ohm UTP station cable for voice shall be used to terminate up to two voice jacks. The first two pairs shall be used to terminate the voice jack with the 3rd and 4th pair used for a second voice jack when installed. Remove only as much jacket as is required for termination and trimming. The manufacturer's guidelines for installation shall be followed. Minimize untwisting of the pairs to less than 1 inch for category 3 voice station cables.

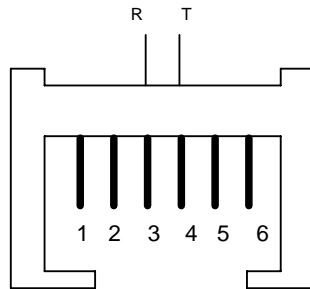

- 2) Data Jack Insert Termination – The data jack insert shall be an 8 position, RJ45 jack insert rated for Category 5 E (enhanced). The 4 pair, 100 ohm UTP station cable for data shall be used to terminate only one jack and all four pairs shall be terminated. Remove only as much jacket as is required for termination and trimming and minimize untwisting of the pairs to less than 1/2 inch. The manufacturer's guidelines for termination shall be followed at all times. The data jack shall be terminated following T568-A pin / pair assignments.

The Category 5E data jack shall perform with stable electrical performance at up to 350 MHz and at a minimum shall meet all of the requirements of ANSI/TIA/EIA 568A, 568B and ISO/IEC 11801 for Category 5 cable. The

Category 5 Enhanced data jack forms one part of a matched impedance structured horizontal cabling channel. The Category 5E jack is part of a structured cabling system that has been warranted by the manufacturers to meet guaranteed performance while working with the selected horizontal cable and patch cords. Data jacks and other hardware recognized for use at FSU may be found in the “OTC RECOGNIZED HARDWARE, MEDIA AND TERMINATION MATERIALS” section. The selected data jack has been recognized as a standard and was selected for optimum performance of the horizontal channel.

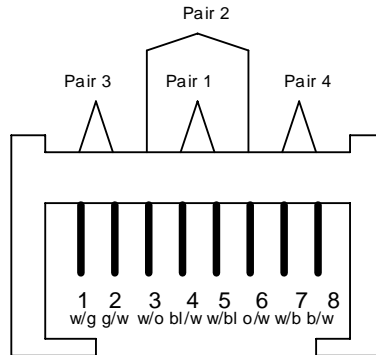

T 568-A

- 3) CATV Jack Insert Termination - CATV outlet – CATV jacks consist of a Type "F" connector snap-in insert. When requested, this insert is to be installed in the bottom positions of the outlet. The CATV coax cable is terminated with a RG6 connector and connected to the outlet.
- d. Additional Jack Inserts Terminations - Additional jacks can be added to the outlet faceplate and shall be based on the customers' special requirements. - Growth in spare slots will be from top to bottom when using an outlet configured for adding modular Telecommunications jacks
 - 1) Fiber outlet - When providing fiber optic connectivity a Corning Universal Transport System / Information Outlet or equivalent must be used. This outlet must be capable of mounting and terminating 1 FDDI or 2 ST Connector sleeves plus a 6 position RJ-11 category 3 USOC voice jack and one category 5E, T568A eight position RJ-45 jack. These modular jacks shall serve as the minimum required voice and data jacks to the station location. All connectors must be side mounted on the device. This station device shall be a Corning

UTS-IO or equivalent. Equivalents require prior approval of the Office of Telecommunications.

- 2) Wall phones and pay phone station terminations - Instruments requiring mounting on walls will use a RJ11 USOC wall jack capable of supporting the instrument. Pay phones do not require a jack but should have station wire coiled in the service box.

ADA Requirements - Outlets in public locations that will require access by the handicapped (i.e. payphones, public phones, etc) have special height requirements for their installation in terms of the "Highest Operable Mechanism". All outlet boxes for these shall meet the following guidelines:

Side Reach – Maximum of 54 inches. If side reach occurs over an obstruction 24" wide and 34" high, the maximum allowed side reach is 46 inches.

Forward Reach – Maximum of 48 inches. If the forward reach occurs over an obstruction 20" to 25", the maximum height must be 44 inches.

2. Horizontal Terminations in Telecommunications Rooms / Terminal Enclosures (MTC / TC)

- a. Horizontal Voice Cable Termination – Voice horizontal cables shall be terminated on a 66M1-50 (50 pair) terminal block on the backboard. All four pairs of the horizontal UTP cable shall be terminated in order (pair 1 thru 4). Up to 12 cables can be supported by one 66M1-50 (50 pair) terminal block. Remove only as much jacket as is required for termination and trimming. The manufacturer's guidelines for installation shall be followed. Minimize untwisting of the pairs to less than 1 inch for category 3 voice station cables.
Horizontal voice cables (station wire) shall be terminated in order on the same terminal block from top to bottom, left to right beginning.
- b. Horizontal Data Cable Termination – Data UTP cables shall be terminated on the relay rack or wall mounted 24 port patch panel. The patch panel shall be equipped with 24 category 5 E RJ45 data jacks. The 4 pair, 100 ohm UTP station cable for data shall be used to terminate only one jack and all four pairs shall be terminated. Remove only as much jacket as is required for termination and trimming and minimize untwisting of the pairs to less than 1/2 inch. The manufacturer's guidelines for termination shall be followed at all times. The data jack shall be terminated following T568-A pin / pair assignments.
- c. CATV Horizontal Cable Termination – CATV RG6 cable shall be terminated with "F" connectors in the CATV Terminal Box. Follow the manufacturer's recommendations for installation.

- d. Fiber Horizontal Termination - all horizontal Fiber Optic cables for data networks and other applications will be routed to the equipment relay rack in the MC, TC or CPE room. Fibers will be terminated with ST (multimode) and SC (single mode) connectors in lockable WIC/PIC panels that are manufactured by Corning. Panels for fiber will be installed in the top most slot of the relay rack. Sizing of these boxes will be done on a case by case basis with the design professional and the OTC involvement.

E. CROSS-CONNECTIONS

1. Voice circuit cross connection – Cross connection between terminals for Voice Circuits will use one pair, twisted, 24 AWG jumper wire. The color of this wire will be White/Blue. No more than one wire shall be punched down (terminated) on a single terminal. A red plastic F clip terminal insulator will be placed over terminals used for Digital instruments, special circuits, T-1's etc., terminated on voice cabling. Jumpers shall utilize wire management (“D” Rings) and shall not be run diagonally. A 2” minimum drip loop shall be provided at each jumper end when terminated. Jumpers in the horizontal cross-connect shall be minimized and shall not exceed 6 meters (20’). The horizontal cross connect jumper length shall be included in the maximum combined jumper length in the telecommunications room of 7meters (23’). Cross connection of horizontal cabling shall meet all recommendations of ANSI/TIA/EIA 568A and 568B.
2. Data Circuits Cross-Connects - Patch Cords for patch panels – Data circuits are terminated in the data patch panels in the Relay Rack. A Category 5 Enhanced pre-connectorized RG45 patch cable shall be used to connect the Horizontal cross-connect jack to the data Hub or other equipment. The data patch cable shall be limited to the needed length for the cross-connect. Cable Management devices shall be used for routing of patch cables. Patch Cables in the horizontal cross-connect shall be minimized and shall not exceed 6 meters (20’). The horizontal cross connect length shall be included in the maximum combined horizontal patch cable and equipment cable length in the telecommunications room of 7 meters (23’). Cross connection of horizontal cabling shall meet all recommendations of ANSI/TIA/EIA-568A and 568B. Data patch cords are part of a structured cabling system that has been warranted by the manufacturers to meet guaranteed performance while working with the selected horizontal cable and termination hardware. Patch cords are normally the responsibility of the individual departments. Patch Cords found in the “OTC RECOGNIZED HARDWARE, MEDIA AND TERMINATION MATERIALS” section are recommended for optimum performance of the horizontal channel.
3. Fiber Optic Jumpers – All fiber optic cross-connect jumpers shall be single fiber Corning fiber Jumpers. Fiber Jumpers shall meet FDDI, ANSI/TIA/EIA 568A and 568B standards. All jumpers shall be pre-connectorized. Multimode fiber riser jumpers shall be 50/125µm, OFNP with SC connectors and shall be sized in length for the application. Single Mode 8.3/125µm should be OFNP with SC connectors and

sized in length for the application. The following color scheme shall apply for fiber jumpers:

Multi-mode	Orange
Single-mode	Yellow

F. LABELING

All Telecommunications infrastructure and equipment components shall be labeled.

1. It is recommended that Cross Connect Fields be color coded for easy field identification. Cross-Connect Field Color Coding:
 - Orange - Demarcation Point (CO)
 - Green - Public Network Connection in Building being served
 - Purple - Common Equipment, PBX, LAN's, MUX, etc.
 - White - First Level Backbone. Main cross-connect to Intermediate cross-connect or horizontal cross-connect.
 - Gray - Second Level Backbone. Intermediate cross-connect to a horizontal cross-connect.
 - Blue - Horizontal Cable.
 - Brown - Inter-building backbone. (campus building to building).
Note: Brown takes precedence over white or gray for inter-building runs.
 - Yellow - Miscellaneous (alarms, security systems, etc)
 - Red - Reserved for future use.
2. Backbone Riser Terminal Labeling –
Backbone riser terminal blocks shall be labeled with the cable number and the pair counts indicated on the designation strip.
3. Horizontal cable termination
 - The voice M1-66 block should be labeled on the designation strip beside the appropriate cable pair with the station outlet number and jack number.
 - The data patch panels should be labeled on the designated strip above each modular jack with the Station Outlet number and jack number.
 - Horizontal Outlet Labeling - Each individual jack in the station outlet should be labeled using the EIA/TIA 606A standard and indicate whether it is voice or data by use of a plug-in icon on the faceplate. Voice jacks will contain the 66 block number and the station cable termination number (1-12). Data jacks shall be labeled using the patch panel number and port number to form the ID for the jack. Room numbers are not used as part of the jack ID number.

Horizontal Outlet Numbering example: data jack 2-02 is patch panel 2 port 2.
4. All labeling will be done with typed inserts, typed on adhesive labels or pre-stamped jack usage indicators. Handwritten labels are not recommended.

V. TELECOMMUNICATIONS GROUNDING AND BONDING

Statement: The information provided in this document for the design of the Telecommunications grounding and bonding system does not replace national, state, local or other applicable codes, laws or regulations.

Telecommunications grounding and bonding is additional grounding and bonding specifically for telecommunications systems and serves to minimize electrical effects and hazards, augment electrical bonding, and lower the system ground reference potential. Requirements and guidelines for this system are found in ANSI/TIA/EIA-607.

A. GROUNDING PRACTICES

1. Grounding Choices –
 - The first choice for connection of the Telecommunications Grounding/Bonding system is direct attachment to the closest point in the buildings electrical service grounding electrode system. Electrical power cabling and Communications cabling must be effectively equalized. (reference NEC 800-40). A 4.0 AWG copper bonding conductor shall be provided to the MC for connection to the Telecommunications grounding and bonding system by a qualified electrician.
 - In buildings without electrical service install a driven ground rod which is ½” in diameter and 8 ft. long.
 - If the ground conductor is installed in conduit or raceway, the conduit or raceway must be bonded on both ends to the ground.

B. TELECOMMUNICATIONS BONDING PRACTICES

1. Routing – when routing bonding conductors the following applies:
 - Use short direct paths for ground conductors used for bonding.
 - Conductors must be routed with minimum bends.
 - Avoid unnecessary connections or splices.
2. Bonding Conductor –
 - Use a 6 AWG stranded copper bonding conductor. The conductor shall be insulated and the color green.
3. Connections – connections are to be made with bolt or crimp connectors or exothermic welding.

C. TELECOMMUNICATIONS GROUNDING / BONDING BACKBONE

1. Telecommunications Buss bars –

- a. Main Grounding Buss bar (TMGB) – The TMGB is the main telecommunications grounding buss bar and is designated as the connection point for protectors. It must safely carry lightning and power fault currents. The following should apply:
- The TMGB should be located in the MTC room on the plywood backboard.
 - Shall be constructed of copper or copper alloy and be capable of multiple connections for the 6 AWG Backbone ground wire and equipment to be bonded in the MTC.
 - Is the point of connection for the building electrical service ground to the Telecommunications ground system
 - Any protection devices used for Telecommunications Outside Plant “exposed” cables should be directly connected to the TMGB.
- b. Telecommunications Grounding Buss bar (TGB) – A TGB shall be placed in each TC room and CPE room and will be the point of connection in that room to the telecommunications grounding / bonding system. The following should apply:
- A TGB should be located in each TC and CPE on the plywood backboard.
 - Shall be constructed of copper or copper alloy and be capable of multiple connections of the 6 AWG Backbone ground wire. (TBB)
 - Shall be directly bonded with 6 AWG conductor to other buss bars.
 - Shall be bonded to building structural steel and other permanent metallic systems if close and accessible in the room.
 - Shall be the approved grounding connection point for all Telecommunications equipment and hardware in the TC or CPE.
- c. Telecommunications Bonding Backbone (TBB) - A TBB should be installed between each Buss bar. The TBB should be a 6 AWG stranded, copper insulated wire with green insulation.
- d. Bonding Connections in MC/TC/CPE – The following shall apply:
- All bonding connections shall be made to the TMGB or TGB with 6 AWG stranded, copper insulated wire with green insulation.
 - All cable trays and conduits shall be bonded.
 - Telecommunications equipment shall be bonded per the manufacture’s guidelines. If bonding is required it shall be made to the TMGB or TGB. Relay Racks shall be bonded to TMGB or TGB.
- e. Cabinets and Terminal Boxes –
- In most applications cabinets and terminal boxes will be installed in the telecom rooms for voice and CATV terminations by cable installation personnel. Those cabinets and terminal boxes will be connected to the copper bus bar or copper multi-tap terminal by cable installation personnel with a No. 6 AWG stranded

copper, PVC insulated electrical grounding wire. In small buildings that may only have a cabinet or terminal box provide a No. 6 AWG stranded copper PVC insulated electrical grounding wire from the main building electrical system ground. The ground should be connected at the closest possible point to the electrical service ground and shall meet all applicable codes. The ground shall be bonded to a copper bus bar or copper multi-tap terminal attached to the cabinet or terminal box.

e. Typical Telecommunications Grounding / Bonding System

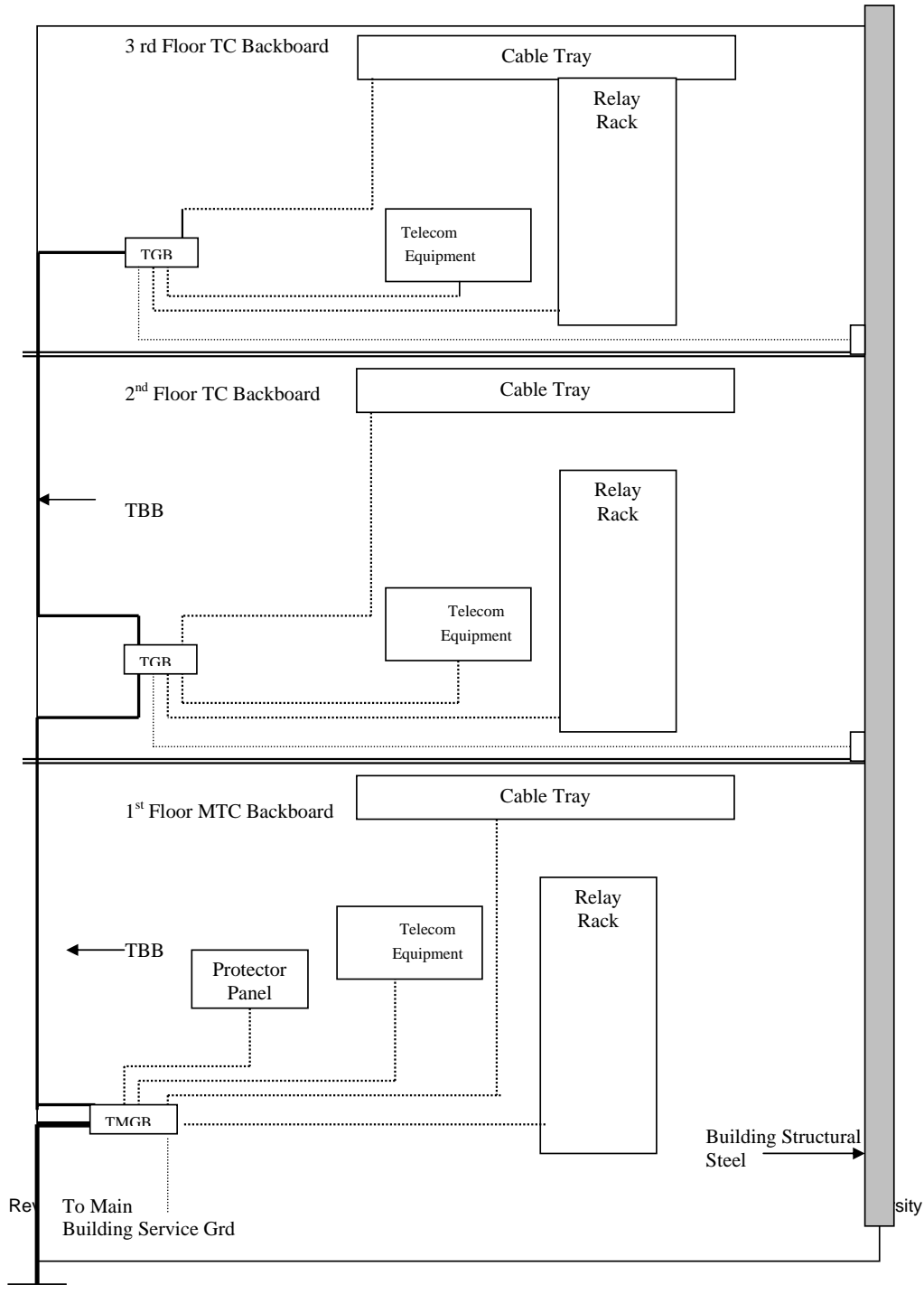

VI. TESTING

Field testing of communications cabling requires a set of measurable transmission performance parameters with necessary field instruments. Acceptance testing of all installed and terminated structured cabling systems, including UTP, STP, Coaxial and fiber Optic cable shall be completed and both a hard copy and electronic copy (“As Built”) provided to the Office of Telecommunications. Horizontal Data Structured Cabling links and channels shall be tested for acceptance.

Testing of telecommunications cabling systems shall meet the following standards:

- ANSI/TIA/EIA 568A and B - Commercial Building Telecommunications Standards.
- TIA/EIA TSB-67 – Transmission Performance Specifications for Field Testing of Unshielded-Pair Cabling Systems.
- Manufacturers testing guidelines.
- Publications and Industry Standards for CATV. Society for Cable Television Engineers (SCTE)
- Code of Federal Regulations (CFR) – 10CFR47, Part 76.605. Signal Quality for CATV. Federal Communications Commission (FCC).

VII. OTC RECOGNIZED HARDWARE, MEDIA AND TERMINATION MATERIALS

The following Hardware, Media and Termination Materials have been selected as standards for the University. Equivalent for any FSU standardized material may only be used if prior approval has been given by the OTC design professional. All materials have been selected based on specifications, the testing of matched systems by manufacturers, distributors, and OTC and proven performance of products in the field at FSU. The parts of the structured cabling system have been warranted by the manufacturers to meet guaranteed overall link and channel performance. These materials are recommended for optimum performance of the horizontal channel.

A. Horizontal Channel

1. Horizontal Media

a. Horizontal Voice Cables –

1) Plenum -

- Category 3, 100 ohm, 24 AWG, 4 pair UTP, Reel in Box, Color – Gray : **Commscope, Part number 3504 or Equiv**

2) Non-Plenum –

- Category 3, 100 ohm, 24 AWG, 4 pair UTP, Reel in Box, Color – Gray:
Commscope, Part Number 35N4 or Equiv
- b. Horizontal and Riser Data Cables –
- 1) Plenum –
 - a) Category 5E, AirES C5ET, 100 ohm, 24 AWG, 4 pair UTP, Reel in Box, Color–Blue: **Krone Wire, Part Number TN5ESP-XX-04**
<http://www.kroneamericas.com>
 - 2) Non-Plenum –
 - a) Category 5E, TrueNet C5ET, 100 ohm, 24 AWG, 4 pair UTP, Reel in Box, Color–Blue: **Krone Wire, Part Number TN5ESR-XX-04**
<http://www.kroneamericas.com>
2. Horizontal Station Outlets –
- a. Outlet Faceplates
 - 1) Flush Wall Faceplate, 6 port, color ash:
Krone, Part Number 6644-1-156-01
<http://www.kroneamericas.com/SEC08.PDF>
 - 2) Surface Wall Faceplate, 2 Port, color ash:
Krone, Part Number 6644-1-122-01
<http://www.kroneamericas.com/SEC08.PDF>
 - b. Modular Jack Inserts -
 - 1) Voice Category 3 Modular Jack Insert, RJ11, USOC, color ash:
Krone, Part Number 6645-1-153-01
<http://www.kroneamericas.com/SEC08.PDF>
 - 2) Data Category 5 E Modular Jack Insert, RJ45 non-keyed, T568A, Color Blue:
Krone, K600 Universal Jack, Part Number 6467-1-081-40
<http://www.kroneamericas.com/SEC08.PDF>
3. Data Patch Panels –
- a. 24 Port (4 - 6 port) 2U, 19”, T568A, Cat 5E Patch Panel with Horizontal wire management:
Krone, Patch Plus, K600 Series, Part Number 6653-1-751-24
<http://www.kroneamericas.com/SEC07.PDF>

4. Data Patch Cords- data patch cords are not normally provided by the OTC. The following patch cords recommended as part of a matched horizontal channel and are recommended for optimum performance.

- a. **Krone, Category 5 Enhanced (C5E) (C5ET), Truepatch Cord RJ45 – RJ45 unkeyed patch cables. Must be used with C5E or C5ET Horizontal Cable for impedance matched system.**
<http://www.kroneamericas.com/SEC07.PDF>

B. CATV Materials

1. Cables –

- a. OSP Trunk Cable – .750 Flooded coax cable:
CommScope, Part Number P3 75-750JCASS
<http://www.commscope.com/product/lan.htm>
- b. OSP Feeder Cable - .500 Flooded coax cable:
CommScope, Part Number P3 75-500JCASS
<http://www.commscope.com/product/lan.htm>
- c. Building Riser Cable – Jacketed Plenum Rated .500 coax cable:
CommScope, Part Number P3 75-500JCA
<http://www.commscope.com/product/lan.htm>

2. Hardware –

- a. Cabinet – 24”H x 18”W x 8”D Cabinet with plywood backboard and locks:
Toner Cable Equipment, Part Number SP-24-V8
<http://www.tonercable.com/home.htm>

C. Fiber Materials

1. Fiber Cables –

- a. OSP Altos Loose Buffer Tube, 18 fiber hybrid (12 SM, 6 MM, 50/125) Optic Fiber Cable:
Corning Part Number 018XW4-141XXA20
<http://www.corning.com/opticalfiber/>
- b. MIC Plenum tight Buffer tube, 6 Multimode fiber, FDDI Performance Plus
Corning Part Number 006C88-31131-29
<http://www.corning.com/opticalfiber/>
- c. Plenum tight buffer, single mode fiber cable
Corning Part Number 370-948-SMOD
<http://www.corning.com/opticalfiber/>

2. Connectors –

- a. SC Single-mode Connector
Corning Part Number 95-200-42
<http://www.corning.com/opticalfiber/>
- b. SC 50/125 Multi-mode Connector
Corning Part Number 95-050-41
<http://www.corning.com/opticalfiber/>

3. Hardware –

- a. Pretium Connector housing
Corning Part Number PCH-04U
<http://www.corning.com/opticalfiber/>
- b. Pretium Splice Tray
Corning Part Number PC4-SPLC-12C
<http://www.corning.com/opticalfiber/>
- c. 2S Splice Tray
Corning Part Number M67-048
<http://www.corning.com/opticalfiber/>
- d. Single-mode LC APC connector Module with pigtail
Corning Part Number CCH-CM12-B3-P03RH
<http://www.corning.com/opticalfiber/>
- e. Multi-mode 50/125 50 SX+ LC connector Module with pigtail
Corning Part Number CCH-CM12-E4-P03SH
<http://www.corning.com/opticalfiber/>
- f. Multi-mode CCH 6 port Connector Panel, simplex SC 50/125 SX+
Corning Part Number CCH-CP06-E7
<http://www.corning.com/opticalfiber/>

D. Multi-pair Cable

1. Non-Plenum Riser Rated Cable (CMR)

- a. Krone cable
 Part Numbers:
 - 25 Pair, 24 AWG – **D2524DO-GY02**
 - 50 Pair, 24 AWG – **D5024DO-GY02**
 - 100 Pair, 24 AWG – **D0024DO-GY02**

- 200 Pair, 24 AWG – **DCC24DO-GY02**
2. Plenum Rated Cable (CMP)
 - a. Krone cable
Part Numbers:
 - 25 Pair, 24 AWG – **VXV2524 – 1902**
 - 50 Pair, 24 AWG – **VXV5024-1902**
 - 100 Pair, 24 AWG – **VXV0024-1902**
 - 200 Pair, 24 AWG – **VXVCC24-1902**
- E. Miscellaneous Materials –
1. Terminals –
 - a. 25 pair 66M1 Protected terminals:
 - 1) **RELTEC, Terminal Block, Part Number R66P25QC
RELTEC, Gas Tube Protector, Part Number S4AB
OR**
 - 2) **Porta Systems Corp., Terminal Block, Part Number 581P-2
Porta Systems Corp., Gas Tube Protectors, Part Number 75BCXN-230V**
 2. Blue Light Emergency Phones
 - a. Tower Emergency Phone Blue Light Unit
Code Blue Corporation, Tower with Phone, Part Number CB922
Note: Tower unit to have circulation vent
<http://www.codeblue.com/>
 - b. Wall Mounted Emergency Phone Blue Light Unit
Code Blue Corporation, Wall Mount unit with Phone, Part Number CB2
<http://www.codeblue.com/>
 3. Outside Plant Pull Cord w/ metallic member (Tone Tape)
Arnco, Part Number DL WP12LC
 4. Elevator Phones – For prepared elevators with pre-stamped panels. **Ramtech, (no front panel), model OEM R833**

VIII. OTHER

A. CAMPUS MASTER PLAN

FSU has developed both a ten year and twenty year campus master plan which will include documentation of telecommunications services for existing and future buildings.

New construction and renovation projects planners should reference this plan and consider the installation of new OSP facilities and support services back to a central distribution point when establishing cost estimates and budgets. Planners should work closely with the OTC and the Central Utilities Plant (CUP) to assure bell circuits, fire alarms, energy management systems are considered and installed.

B. INSPECTION AND TESTING DURING AND AFTER INSTALLATION

Frequent inspections should be conducted during the installation of the new services and wiring. These inspections should be conducted jointly by the University's project manager and the staff person directly responsible for building services. It is important that the design engineer work with the OTC, ACNS, and the University Project Coordinator to outline the specific tests the contractor must perform to gain acceptance of the new services. All finished test results shall be delivered to the Office of Telecommunications. Failure to do so will place the project in an incomplete status and shall stop final payment due installer.

C. COIN OPERATED TELEPHONES

Unless otherwise specified, provisions shall be made for public coin operated telephone facilities in public access areas. If only one coin operated telephone facility is required, it shall be located to permit usage by handicapped individuals. The telephone outlets for public coin operated telephones shall be located at a height that will permit the installation of normal height telephone mounts and/or lowered height telephone mounts for the handicapped without exposure of the telephone outlets for either installation. All public access telephones shall meet the American's with Disabilities Act of 1992.

D. BLUE LIGHT EMERGENCY TELEPHONES

The construction budget for renovations or new facilities should include the costs of conduit, Talk-A-Phone Emergency Telephones and hardware necessary to install emergency phones. The Office of Telecommunications installs the cabling and telephone line required. The exact location of instruments shall be recommended by the Public Safety Office within the Florida State University Police Department.

Talk-A-Phone units require AC power for the lighting which should be dedicated, 20 Amp, Non-switched service. The two most common Units which are to be used for exterior installations are listed below. Model numbers and features change frequently so the Office of Telecommunications should be contacted for current model numbers:

4. Blue Light Emergency Phones

c. Tower Emergency Phone Unit

Talk-A-Phone, Tower with ETP-400 Phone, Part Number ETP-MT/R-FSU

Note: Tower unit to have circulation vent

- d. Wall Mounted Emergency Phone Unit
Talk-A-Phone, Wall Mount unit with ETP-400 Phone, Part Number ETP-WM-FSU/400

Internal Emergency Phones – Emergency phones located inside require the following:

A dedicated 1”” homerun conduit shall be run from the telecommunications room for the voice line to a FME – Flush Mount Enclosure box where the phone is to be installed. **See ADA requirements for height of the enclosure.** A 120 volt A/C, 20 amp dedicated circuit shall be provided to a single gang outlet mounted in the bottom of the FME Box. The design professional should consult with the OTC concerning the university instrument of choice or any required signaling devices.

E. ELEVATOR TELEPHONES

The construction budget for renovations or new facilities should include the costs of elevator telephones. The OTC will install and maintain all elevator telephones on campus; however, the design professionals must ensure that the conduit is installed. Instrumentation cost shall be budgeted by the construction manager.

F. WIRELESS APPLICATIONS

In today’s complex wiring environment sometimes wired services equal wireless services. If the design professional sees a need for wireless applications or has a request from the customer they should consult the Office of Telecommunications. This would include wireless application in the areas of data or voice or video.

G. DOCUMENTATION

At the completion of each installation “As Built” prints and other supporting documentation shall be provided by those performing work specified in this document. Prior to the beginning of university major and minor construction projects, a complete set of 100% prints and documentation shall be provided to the OTC Engineering group for review and will be maintained on file.

IX. APPLICABLE CODES AND STANDARDS

The design and installation of FSU telecommunications infrastructure attempts to meet parameters of all applicable local, state and national codes and standards. Issues that fall under codes are a requirement. Though many telecommunications design issues fall under established standards that are not code, these standards have been adopted at FSU and it is highly recommended by this office that the standards listed in this document be followed. At times, conflicts arise between published guidelines such as REA, EIA, TIA, NFPA, IEEE,

NCTA, BICSI, and individual company policies. Therefore, this document reflects portions of and/or references the following specifications. Drawing and design documents should be specific for each project and include, either as a direct excerpt or by reference, information from these sources:

- AT&T, former Bell System Practices (BSP's)
- General Telephone, installation and construction practices
- Northern Telecom, installation practices
- RUS (formerly REA), Rural Utilities Services USDA/RUS
- BICSI, Telecommunications Distribution Methods Manual
- ANSI/TIA/EIA-568A, Commercial Building Telecommunications Cabling Standard.
- ANSI/TIA/EIA-568B, Commercial Building Telecommunications Cabling Standard
- TIA/EIA TSB-67 Transmission Performance Specifications for Field Testing of Unshielded Twisted Pair Cabling Systems.
- TIA/EIA TSB-75, Additional Horizontal Cabling Practices for Open Offices.
- ANSI/TIA/EIA-569A, Commercial Building Standard for Telecommunications Pathways and Spaces.
- ANSI/TIA/EIA-606, Administration Standard for Telecommunications Infrastructure of Commercial Buildings.
- ANSI/TIA/EIA-607, Commercial Building Grounding and Bonding Requirements for Telecommunications.
- ANSI/NFPA-70, National Electrical Code
- NFPA-101, Life Safety Code
- NFPA-780, Standard for the Installation of Lightning Protection Systems.
- Other applicable NFPA Codes.
- ANSI/IEEE Codes, All Applicable Codes.
- NESC, National Electrical Safety Code (ANSI/IEEE C-2, overhead and underground telecommunications cable).
- ISO/IEC 11801, Information Technology. Cabling for Customer Premises.
- IEC 603-7, Part 7, Modular Connectors
- FCC Part 68, Connection of Terminal Equipment to the telephone network.
- FCC Part 15, Radiation Limits.
- FCC Part 76, Cable TV Service. Code of Federal Regulations (CFR) – 10CFR47, Part 76.605. Signal Quality for CATV. Federal Communications Commission (FCC).
- Publications and Industry Standards for CATV. Society for Cable Television Engineers (SCTE)
- Local Uniform Building Codes
- National Cable Television Association Handbook
- General Instruments/Hewlett Packard, broadband testing procedures
- Individual university facility and construction guidelines
- Department of Management General Services, Division of Communications, State of Florida.
- Americans with Disabilities Act, 1992

Finished drawing and design documents should not conflict with the above standards and should not deviate from the intent or spirit of this document. It is the responsibility of the design professional for all designs to meet the most current codes and standards at the time of construction.

X. GLOSSARY OF TERMS

ADA	Americans with Disabilities Act
Aerial Service	Telecommunications Cable installed on supporting structures such as poles, sides or buildings, and other structures.
ANSI	American National Standards Institute
ASTM	American Society for Testing and Materials
AWG	American Wire Gauge
Backboard	Plywood covered wall in telecommunications room or in terminal boxes used to mount termination devices, hardware and equipment.
Backbone	Cabling and pathway used to connect the telecommunications rooms, cross-connects, entrance facilities and equipment rooms.
Bridge Tap	The connection of two circuits in parallel to each other or a cable pair continued beyond the point at which the pair is connected to an instrument.
Buried Service	A cable installed under the surface of the ground (not in conduit) in such a manner that it cannot be removed without disturbing the soil. Also called direct buried cable, trenched, or bored.
Busbar	A copper bar used as a common point for connection of the building electrical service ground to all telecommunications hardware and equipment in a room or terminal box.
Cable Bend Radius	The radius that a cable can bend before risk of damage or decrease in transmission performance.
CATV	Community Antenna Television (Cable TV)
Coax	Coaxial Cable. A central conductor surrounded by dielectric and a tubular outer conductor.

Conduit Ductbank	An arrangement of conduit ducts in tiers, encased in concrete used for installing telecommunications cables between buildings.
CPE Room	Customer Premise Equipment Room. Often called Data Equipment Room. This room houses private departmental / customer equipment.
Cross Connection	A connection made between cables, subsystems and equipment by the use of patch cables, or jumper wires run between the terminating devices.
CUP	Florida State University Central Utility Plant.
D Ring	Cable Management Device attached to the backboard.
dB	Decibel
Demarcation point	A point of interface where two services are connected. An example at FSU would be the point at which the local dial tone provider terminates their cables in the Main Telecommunications Room for cross-connection to the Intrabuilding cabling.
EIA	Electronics Industries Association.
EMI	Electromagnetic Interference. An unacceptable or undesired response, malfunction, degradation, or interruption to the intended operation of electronic equipment caused by the coupling of electrical or magnetic fields.
EMT	Electrical Metallic Tubing
Encased Conduit	Conduit contained inside poured concrete.
Exposed Cable	Any cable that is located so that it is subject to lightning, power induction, or differences in ground potentials.
F Connector	Coaxial Connector commonly used for terminating CATV Cables.
Outlet Faceplate	A plate or cover which holds multiple communications jacks, mounted on a surface, and covering the electrical box and communications cables in the wall.
FCC	Federal Communications Commission
FDDI	Fiber Distribution Data Interface

Foot-Candle	a unit of illuminance on a surface that is everywhere one foot from a uniform point source of light of one candle and equal to one lumen per square foot
Gas Tube Protector	An Overvoltage Protector with metallic electrodes in a gas atmosphere contained in a glass or ceramic envelope.
Horizontal Channel	The Horizontal cabling which includes all elements of the Horizontal cabling Link, plus the equipment cords in the telecommunications room and the work area. Contains all elements needed to support telecommunications applications over the horizontal cabling.
Horizontal Link	The horizontal cabling which includes all horizontal components except for equipment cords in the telecommunications room and at the work station.
ICEA	Insulated Cable Engineers Association
IDF	Intermediate Distribution Frame. A field of termination devices on which the intrabuilding backbone cables are terminated for cross-connection to the horizontal cabling system. Normally found in the Telecommunications Room on each floor.
IEC	International Electromechanical Commission.
IEEE	Institute of Electrical and Electronics Engineers, Inc.
Interbuilding Backbone	A Cable between two buildings.
ISDN	Integrated Services Digital Network. A integrated data network in which the same time division switches and digital transmission paths are used to establish connection for different services.
ISO	International Standards Organization
KV	KiloVolts (1000 volts)
LAN	Local Area Network. A geographically limited data network used for the local transport of voice, data, and video.
Loose Buffer	In a fiber optic communication cable, one type of component used to encapsulate one or more optical fibers for the purpose of providing such functions as mechanical isolation, protection from physical damage and fiber identification. The buffer may take the form of a miniature conduit, contained within the cable and called a loose

	buffer, or loose buffer tube, in which one or more fibers may be enclosed, often with a lubricating gel.
Maintenance Loop	An additional length of cable on the end of a installed cable that allows for later use if any of the cable must be shortened or the termination devices moved.
Manhole	A hole through which a person may gain access into a underground vault or structure.
Marker tape	A plastic tape placed in the ground to identify buried cable location if dug up.
MDF	Main Distribution Frame. Also called the Main Cross-connect. The cross-connect in the Main Telecommunications Room (room) where the entrance cables terminate and cross-connect to the building Intrabuilding Backbone Riser cables.
Media	The physical path for telecommunications services. (i.e., copper cable, fiber optic cable, coaxial cable, radio, etc.)
Mhz	Megahertz. One million hertz or one million cycles per second.
Modular Jack insert	The modular communications jack that snaps into a faceplate.
MTC	The Main Telecommunications Room (room) for the entire building. This room serves as the entrance facility for the building where all Outside Conduits terminate. It houses the Main Distribution Frame (MDF), where the service entrance cables terminate and interface with the intrabuilding backbone distribution cabling system and to the horizontal cross-connect and cabling serving that floor. The MDF is considered the point where the regulated telephone company will install the building entrance protectors.
Multimode Fiber	An optical fiber that supports the propagation of more than one bound mode. A multimode optical fiber may be either a graded-index (GI) fiber or a step-index (SI) fiber.
MUX	A device that combines multiple inputs into an aggregate signal to be transported via a single transmission channel.
NEC	National Electrical Code.
NESC	National Electrical Safety Code.

NFPA	National Fire Protection Association.
OFNP	Optic Fiber Non-conductive Plenum.
OSHA	Occupational Safety and Health Administration.
OSP	Outside Plant. Telecommunications facilities located outside of the building. Either Underground, direct buried or aerial.
OTC	Office of Telecommunications
Outlet	A faceplate with modular jacks located at the workstation.
Pathway	Structures that conceal, protect, and support telecommunications cables. (i.e. Conduit, cable rack, trays, J-hooks, underfloor ducts, cellular ducts, trench ducts, Raised access floor, etc.)
PBX	Private Branch Exchange. Telephone system usually serving as a small Central Office for the individual business and located on their site. Provides access to the public switch network.
PE Cable	Filled Cable for use in OSP applications. Designated by the Rural Utilities Service.
Plenum rated	Cable used in a designated area, closed or open, used for the transport of environmental air.
PSI	Pounds per Square Inch
Pull Box	A device to access a raceway, used for access to allow for pulling cable.
Pulling Eye	Metal loop securely fixed to the end of a cable or anchored in the wall of a manhole to allow for the pulling of the cable into the ductbank.
PVC	Polyvinyl Chloride
Raceway	An enclosed channel or pathway designed to hold cables.
Relay Rack	A vertical frame upon which one or more units of equipment and patch panels are mounted.
RFI	Radio Frequency Interference. Any Radio Frequency disturbance that interrupts, obstructs, or otherwise degrades or limits the effective performance of electronics/electrical equipment.

Riser Cable	Intrabuilding Backbone Cable that runs vertically to the IDF in a Telecommunications Room (room).
Single Mode Fiber	A optical fiber in which the signal travels in one mode. The fiber has a small core diameter, typically 8.3 μm .
Sleeve	A Conduit placed through a wall or floor to allow the passage of telecommunications cables.
Solid State Protector	An Overvoltage Protector using high-power semiconductor technology providing fast action and balanced circuits.
STP	Shielded Twisted Pair. A transmission line composed of a twisted 2-wire metallic transmission line surrounded by a sheath of conductive material that protects it from the effects of external fields and confines fields produced within the line.
Sump, Manhole	A fitting at the lowest point of the manhole floor used to pump a manhole dry before working in it.
T-1 (Carrier)	A digital transmission system which operates on two twisted pairs at a speed of 1.544 Mbps. The system is capable of carrying 24 channels (individual circuits) at 64Kbps.
TBB	Telecommunications Bonding Backbone. A 6 AWG or large copper conductor that provides for direct bonding and runs from the Telecommunications Main Bonding Busbar to the bonding busbar in each TC and CPE room.
TC	Telecommunications Room. The Telecommunications Rooms (TC) are “floor serving” and at least one is located on each floor. The IDF and Horizontal cable for the floor are usually located in the TC.
Telecom	Telecommunications
Terminal Block	An insulating base with binding posts used to terminate telecommunications cables and cross connect between cables.
Terminal Box	A metal box with a hinged lockable door used for installing terminal blocks, terminating cables and cross connecting. The box provides protection against dust, mechanical damage, weather and vandalism.
TIA	Telecommunications Industry Association

Tight Buffer	A tight buffer consists of a polymer coating in intimate contact with the primary coating applied to the fiber during manufacture. The protective thermoplastic coating is normally a diameter of 900 microns.
TMGB	Telecommunications Main Bonding Busbar. The main bonding busbar is located in the Main Telecommunications Room and provides a connection point for the main building electrical service ground to safely carry lightning and other power fault currents away from the telecommunications systems. The TBB to other Telecommunications Rooms is connected to the TMGB.
TSB	Technical Service Bulletin
Underground Cable	A telecommunications cable installed in a underground duct system which separates the cable from direct contact with the soil.
UPS	Uninterruptible Power Supply
USOC	Universal Service Order Code
UTP	Unshielded Twisted Pair. A transmission line composed of a twisted 2-wire metallic transmission line surrounded by a sheath of non-conductive material.
Wire mold	A surface mounted enclosed channel designed to hold cables.
Workstation	An individual user interface where the desk, computer, communications, and other equipment is located and connected to the telecommunications outlet.

XI. ILLUSTRATIONS

Illustrations are to aid the design professional and installer in the development and installation of a telecommunications infrastructure in new and existing (renovation) projects. It includes recommended layouts for various infrastructure components and systems.

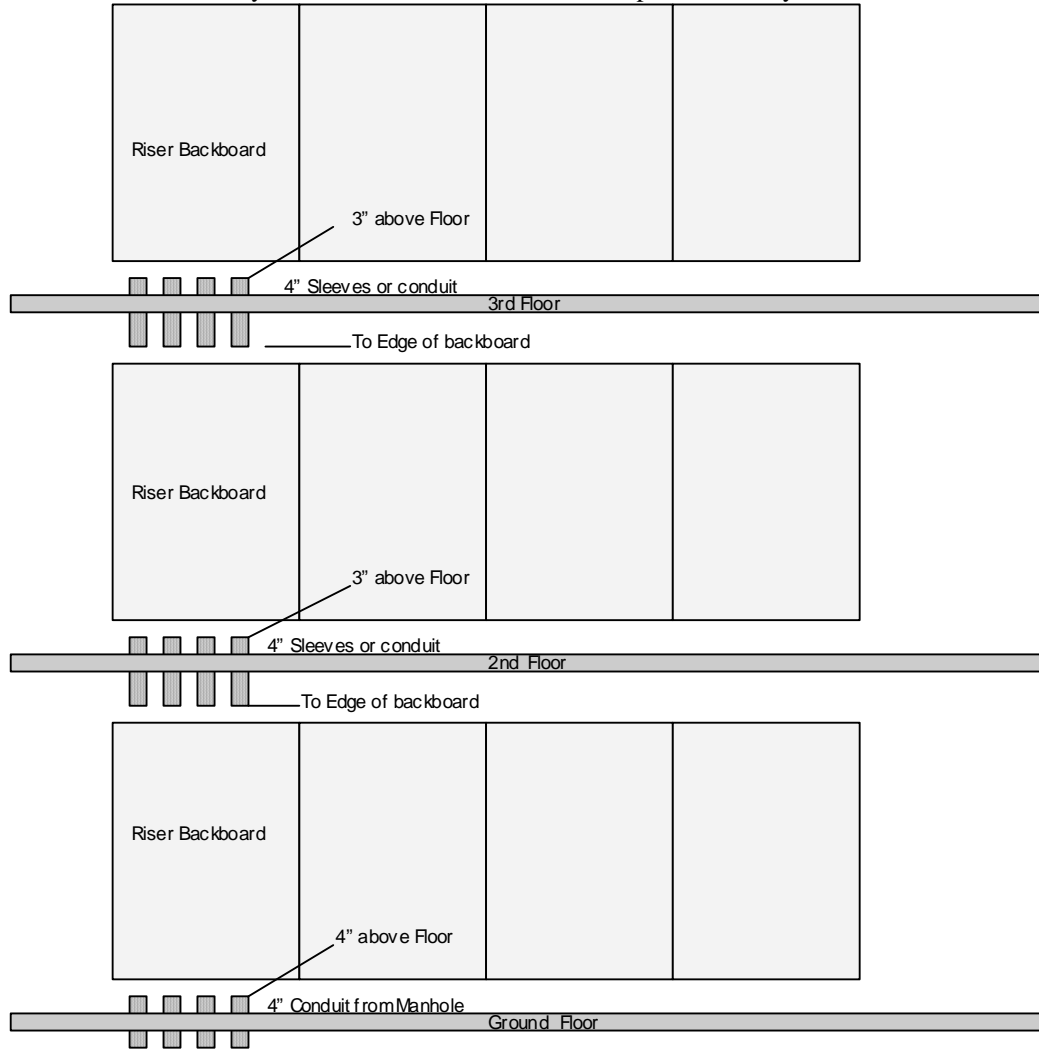

Revision 2.2e

Office of Telecommunications

Florida State University

www.otc.fsu.edu
 Note: All Conduit and Sleeves are to be clean, dry, unobstructed, reamed, labeled, capped for protection and fitted with bushings. Conduit is to be provided with pull tape with a minimum pull rate of 200 lbs.

Fig 1. RISER CONDUIT LAYOUT

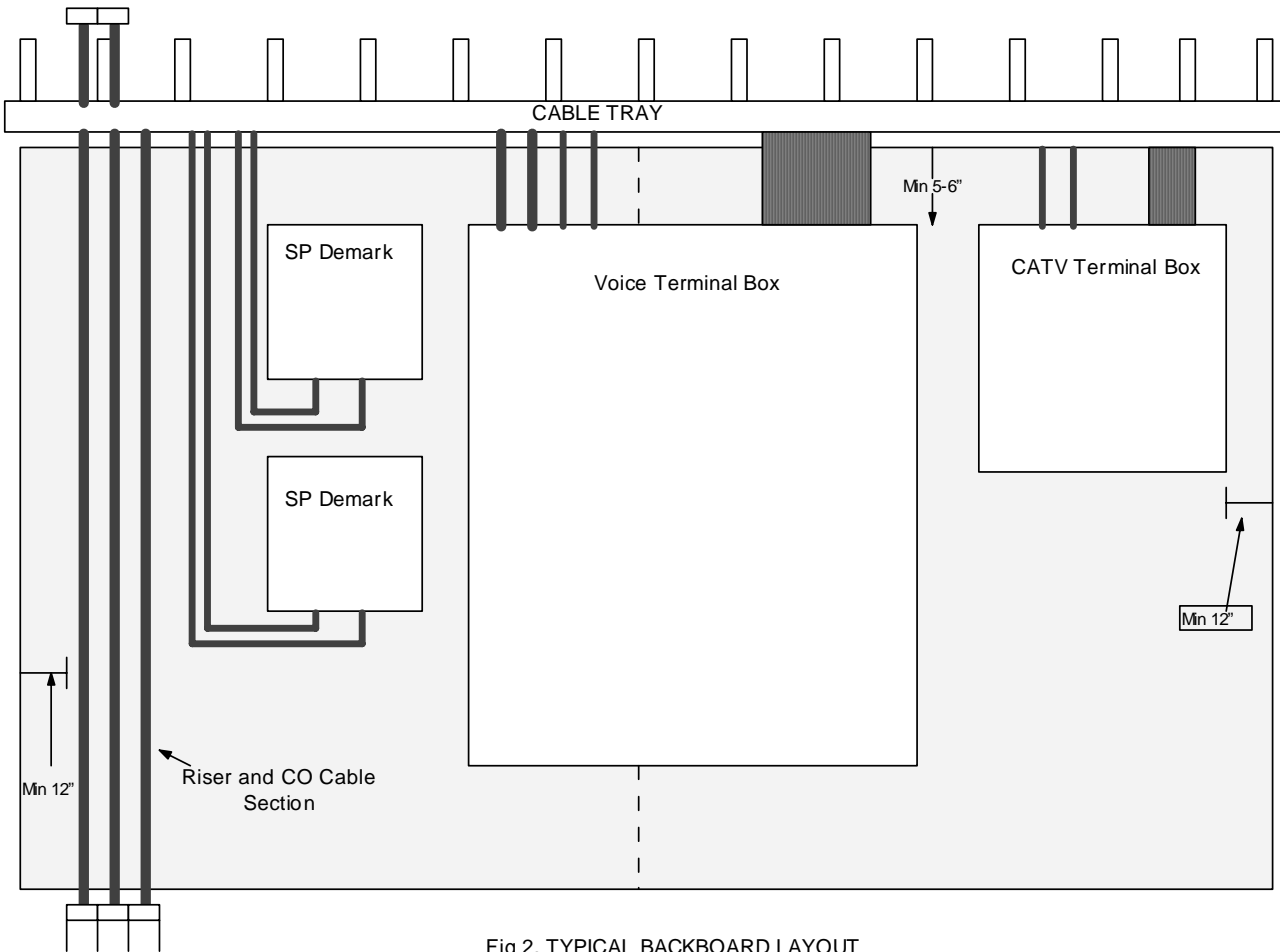

Fig 2. TYPICAL BACKBOARD LAYOUT

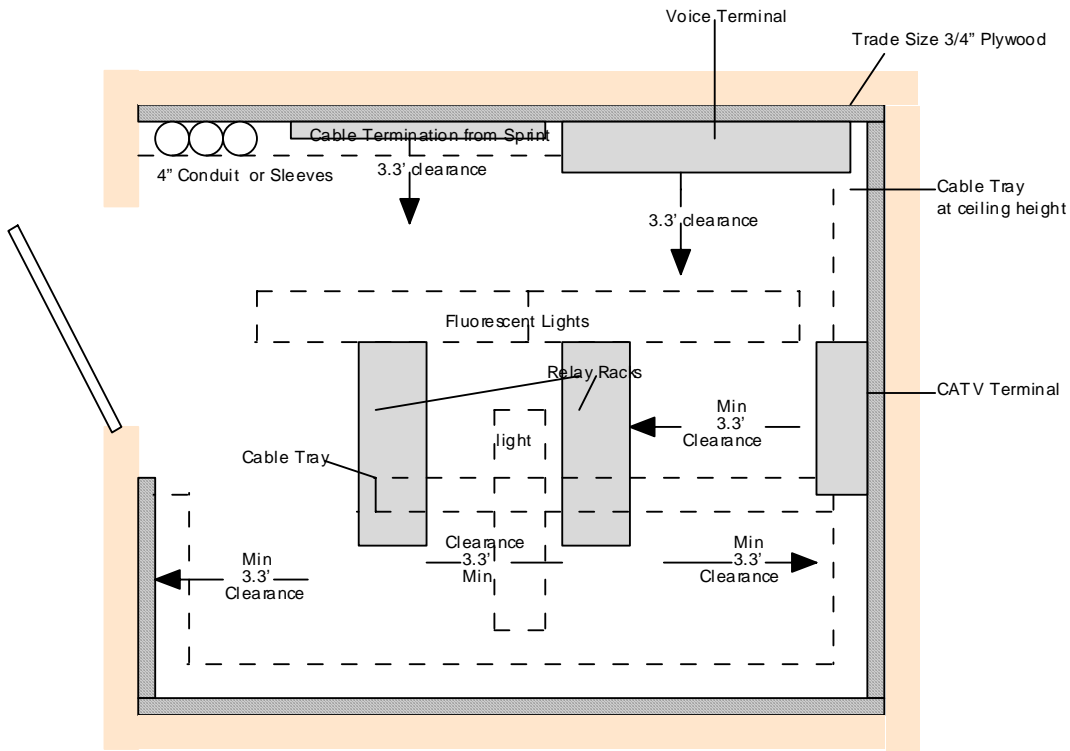

Fig 3. TYPICAL TELECOMMUNICATIONS ROOM
MINIMUM 7' X 10'

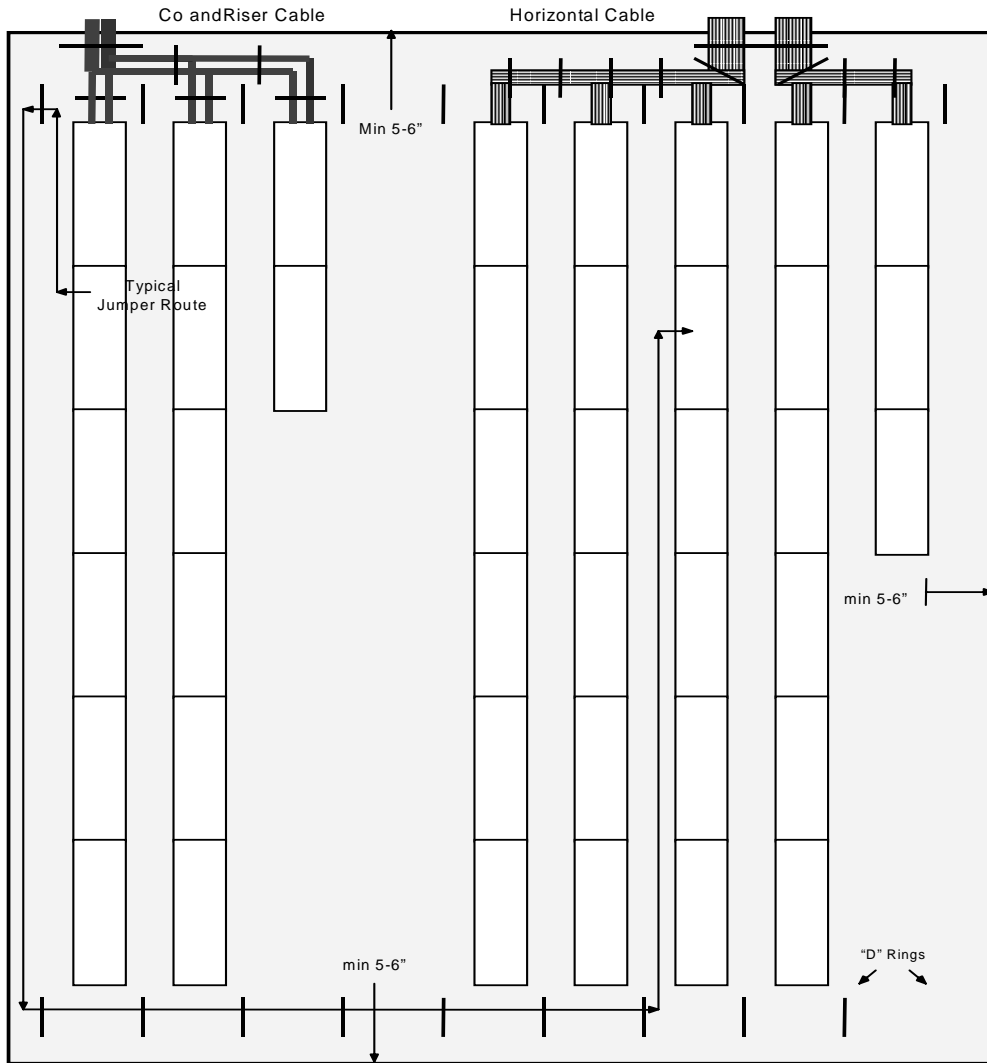

Fig 4. Typical Voice Terminal Can

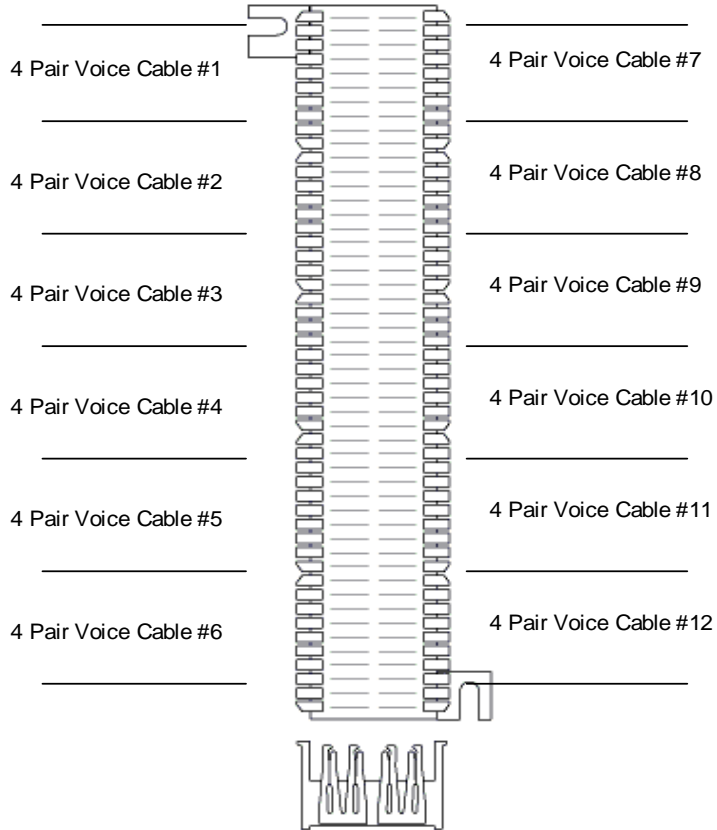
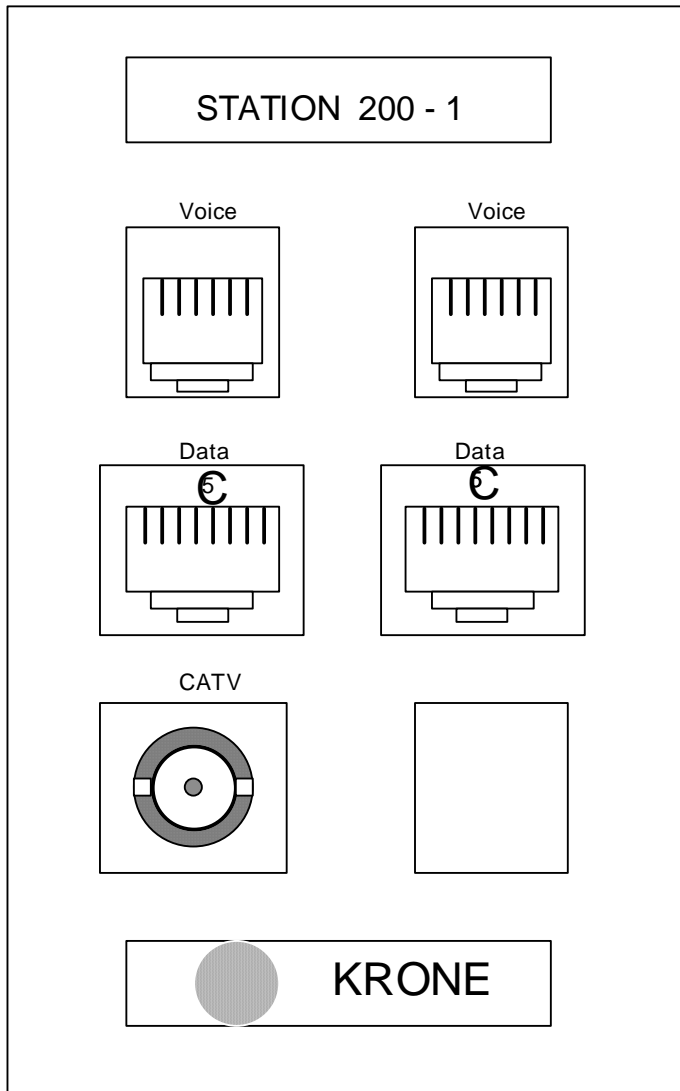

Fig 5. VOICE TERMINATION - S66-M1 50 PAIR BLOCK



Office of Telecommunications
Florida State University
Fig 6. Krone Faceplate Configuration

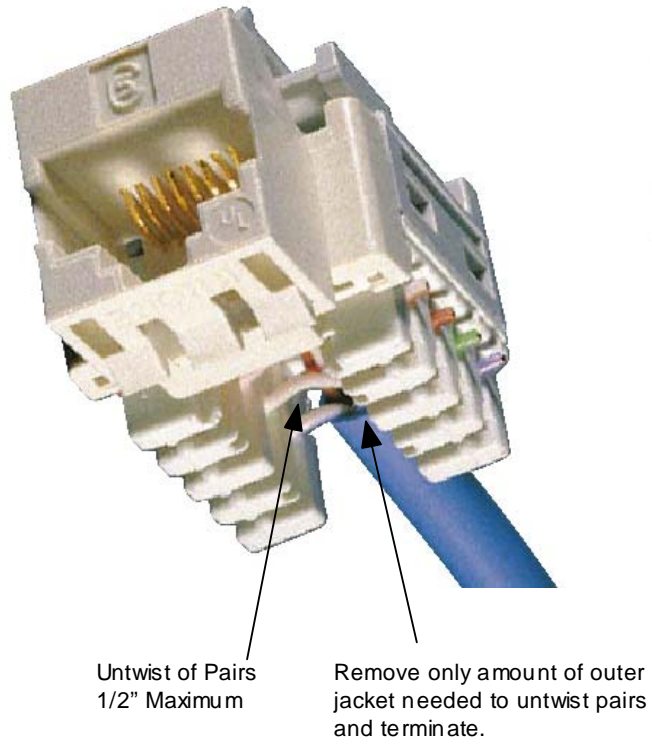

Fig 7. CATEGORY 5E JACK INSERT TERMINATION

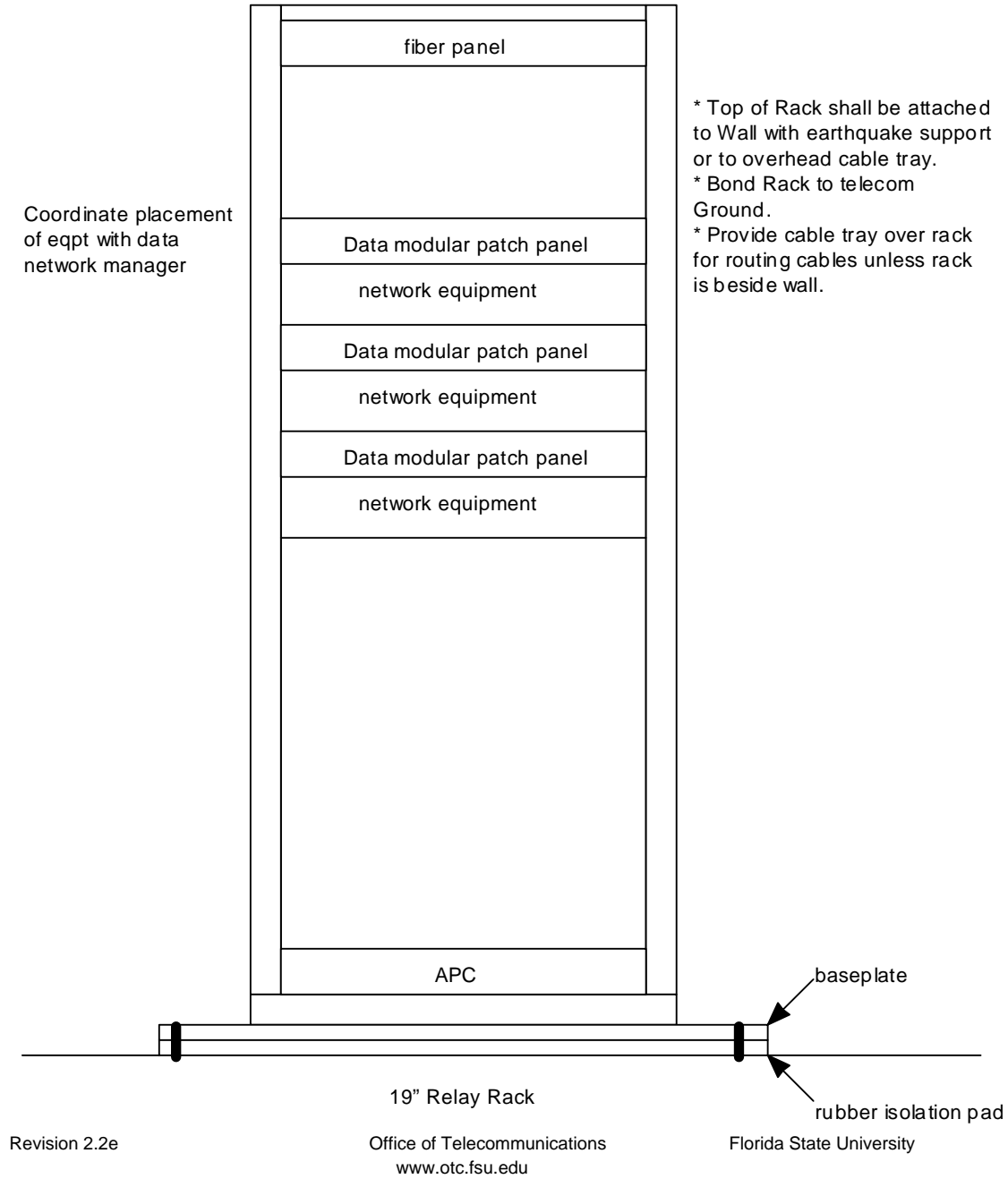

Fig 8. Typical Relay Rack Layout

FSU Elevator Telephone Template - 2005

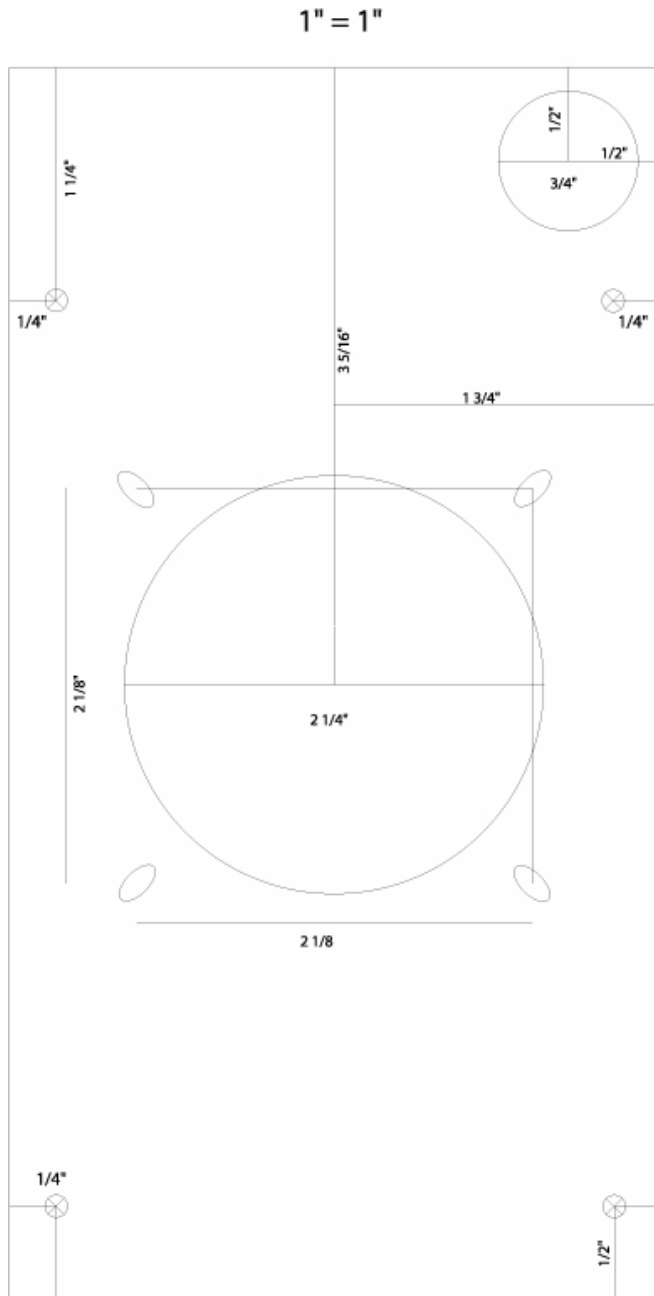

Figure 9 – Elevator Telephone Template